



TECTONUS

RESILIENT SEISMIC SOLUTIONS



INTRODUCTION & DESIGN GUIDE

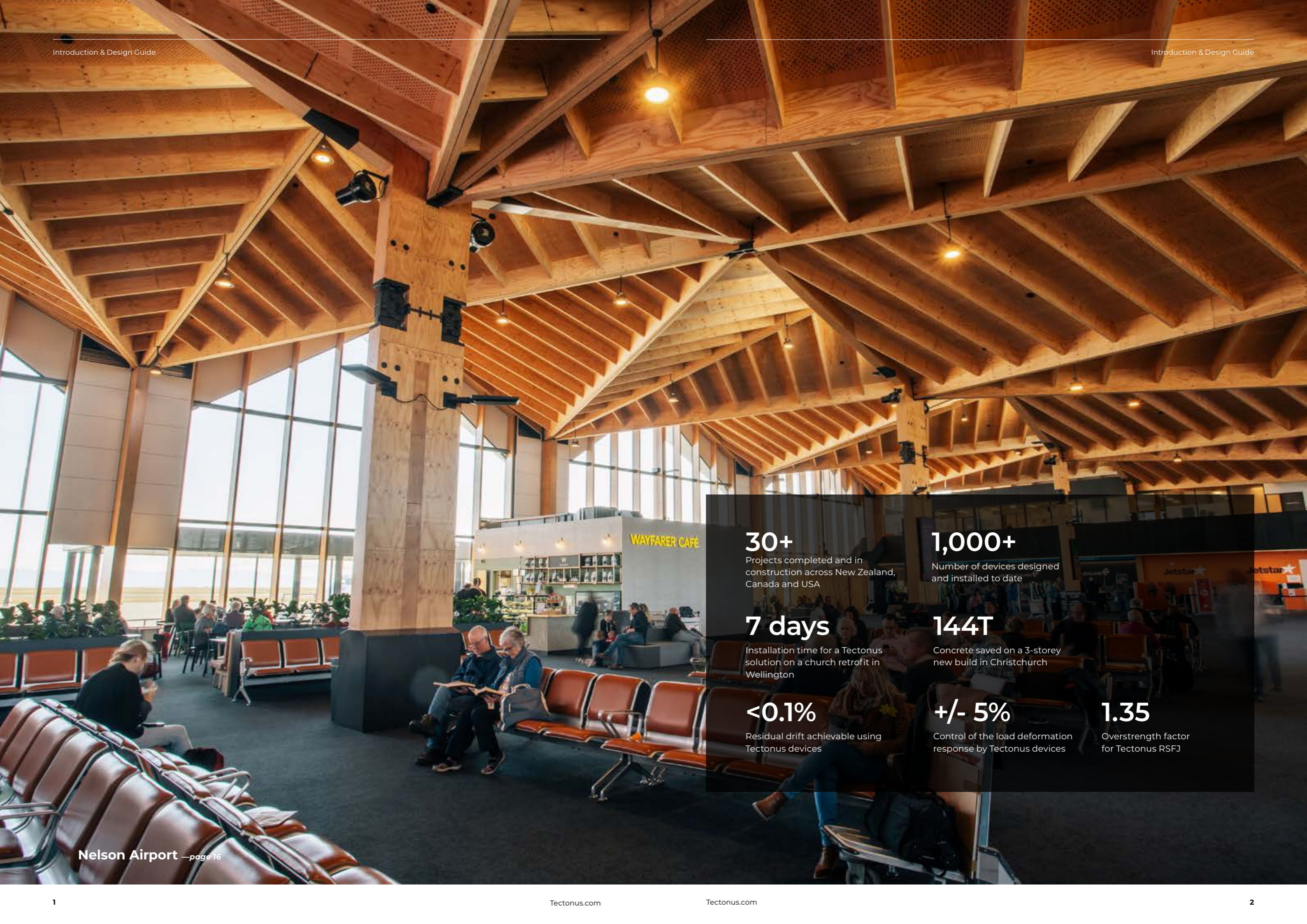

30+

Projects completed and in construction across New Zealand, Canada and USA

1,000+

Number of devices designed and installed to date

7 days

Installation time for a Tectonus solution on a church retrofit in Wellington

144T

Concrete saved on a 3-storey new build in Christchurch

<0.1%

Residual drift achievable using Tectonus devices

+/- 5%

Control of the load deformation response by Tectonus devices

1.35

Overstrength factor for Tectonus RSFJ

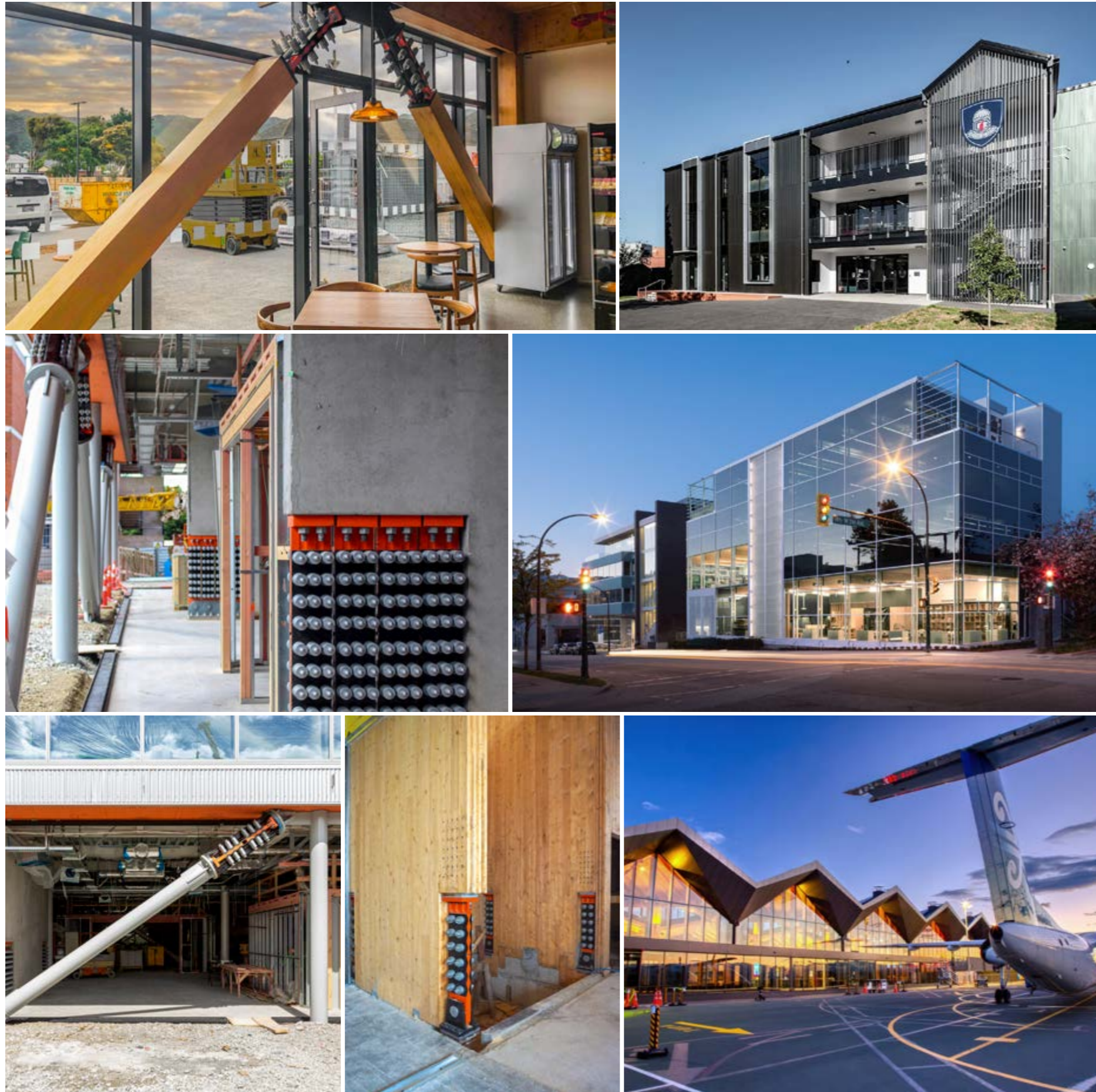

Thank you to our project partners for sharing project photography: **oN5 Office Building**: Credit KK Law, courtesy of naturallywood.com
Fast+Epp Office: Credit-Michael-Elkan | **Nelson Airport**: Nelson Airport & Partners

CONTENTS

Introduction	6
Feature Projects	12
Lincoln University—Waimarie	14
Keith Drive Office Building	16
Nelson Airport	18
Oxford Terrace	20
Tsawwassen First Nation Elders Centre	22
Hutt Valley Health Hub	24
Fast+Epp Head Office	26
48 Greys Ave	28
Cathedral College	30
oN5 Office Building	32
Tawa Church	33
Upcoming Projects	34
Retrofit	36
Design Guide – RSFJ	42
Product Guide	44
Product Table	46
Structural Modeling Guide	48
Design Guide – DFFJ	62
Overview	63
Structural Modeling Guide	64
Product Table	66
From Design to Site	68
Production & Quality Control	70
Delivery & Installation	71
Finishings—Colours & Covers	72
Technical Support Services	74
Test Results 2015 to 2024	76
Storage Tanks	94
About Us	98
Seismic Innovation	99
Our Journey	101

ASSET PROTECTION AND OPERATIONAL CONTINUITY

The building code provides for life safety in a significant seismic event; it doesn't directly address damage avoidance or downtime. Experience from major earthquakes shows that even minor structural damage can lead to extensive downtime and even demolition

since the cost of repairs are greater than rebuilding from new. For forward-thinking organizations this represents a serious threat to long term asset protection and operational continuity.



Tectonus Advantage

Tectonus believes the minimum life safety standard isn't good enough. Our technology and structural design ethos specifically addresses post-quake damage and downtime.

In addition, the devices require no repair or replacement for a design level earthquake (as determined by the

engineer). The device has a secondary fuse which provides an additional 50% displacement capacity above the design level earthquake, providing ultimate peace of mind and a future-proofed solution.

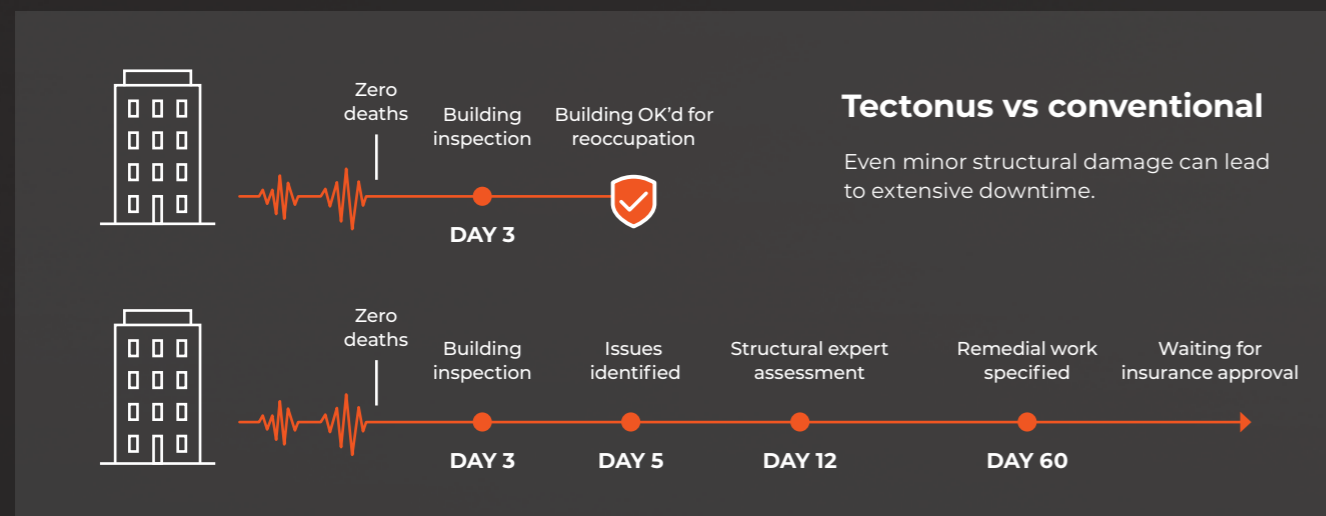

COST-EFFECTIVE SEISMIC COMPLIANCE

Tectonus offers a cost-effective solution for seismic compliance by reducing seismic demand on the structure and by way of its best in class capacity design factor. This allows smart engineers to unlock significant cost savings in structure and foundations.

- Seismic compliance means dealing with a certain level of seismic demand.
- Increased damping and ductility reduce seismic demand
- Reducing seismic demand reduces forces on structure and foundations.
- Reducing forces on structure and foundations leads to savings in materials, transport, and installation time.

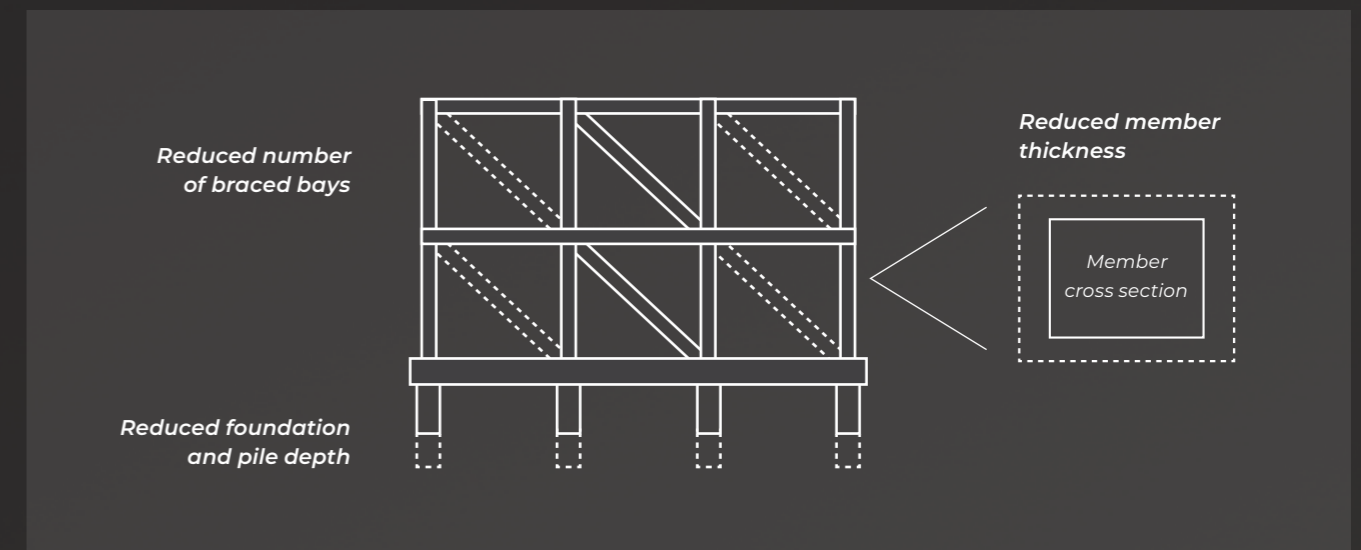

Tectonus Advantage

Tectonus has been shown to reduce seismic demand up to 400% compared to conventional systems and 40% compared to bucking restrained braces (BRBs).

This is achieved in two ways:

- Extra damping. Tectonus increases damping by up to 50%. By adding high levels of energy dissipation to the structure, the rest of the structure is having to deal with less seismic demand. This allows smart engineers to unlock savings in the superstructure and substructure as shown above.
- Best-in-class capacity design factor. Capacity design factor is a margin for error from uncertainties in design, manufacture and installation of seismic connections. A typical capacity design factor of 2.0 means adjacent structural members must be designed to cope with

two times the force capacity of the seismic device. Tectonus devices have a capacity design factor as low as 1.15. This allows smart engineers to design the rest of structure for lower forces, unlocking further savings.

The Net Result

- Taking into account the savings unlocked in the superstructure and substructure, Tectonus devices typically pay for themselves. In several cases, the savings in the superstructure alone are enough to cover the cost of the devices.
- Since the devices pay for themselves, the post-quake benefits of damage avoidance and fast functional recovery are effectively free.

TIMBER BRACES



STEEL BRACES



CONCRETE SHEARWALLS



TIMBER SHEARWALLS



TENSION-ONLY BRACES



MOMENT RESISTING FRAMES



TECTONUS DFFJ

Straight swap for a BRB, with 50% savings in structural actions

A cost effective way to introduce ductility with high levels of damping, the DFFJ is a more conventional friction damper that has been optimized for stability and durability.

DFFJ Damage Free Friction Joint

- High damping (up to 50%)
- Capacity design factor 1.15
- Cost effective
- Fast leadtime
- For economical low damage buildings

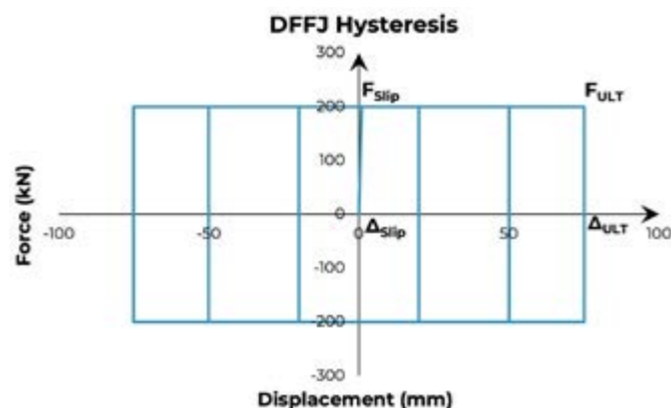

TECTONUS RFSJ

Like base isolation only 2-3x more affordable

Providing damping and self centering all-in-one, the RFSJ delivers very high levels of seismic resilience in a compact and ready-to-install package.

RFSJ Resilient Slip Friction Joint

- True self-centering behavior
- Damping 15-20%
- Capacity design factor 1.35
- Near zero residual drift
- For fast functional recovery

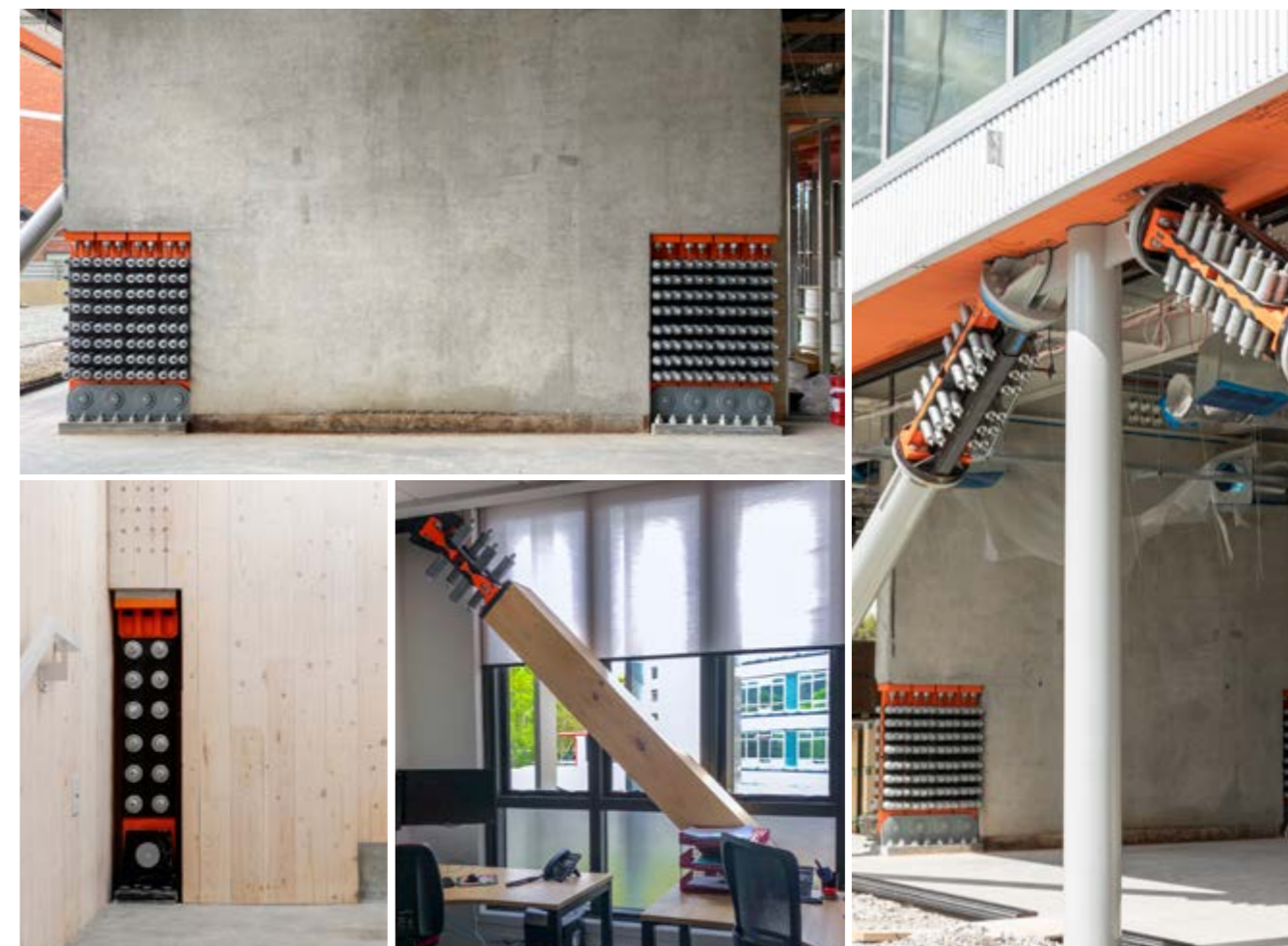
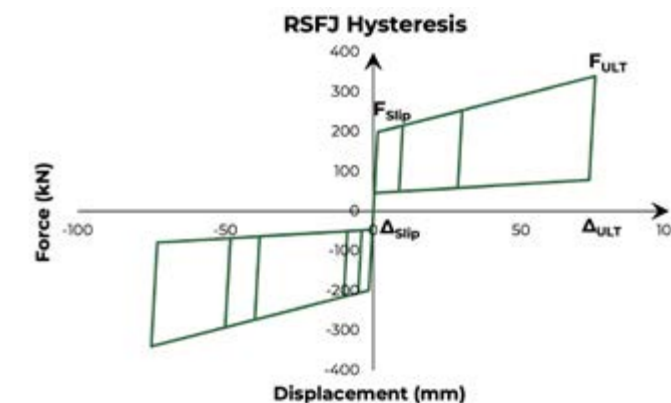



FEATURE PROJECTS

Engineer / BECA
Main Contractor / Leighs Construction

Architect / Warren & Mahoney

LINCOLN UNIVERSITY —WAIMARIE

Christchurch, New Zealand

The Challenge

Lincoln University's new flagship science facility - Waimarie - was in the latter stages of concept design when the engineer introduced Tectonus as an option. The client set the engineers the challenge of a Tectonus-based low damage design for the same cost as the original conventional approach.

The Impact

The proposed design enabled removal of two concrete shear walls from the conventional design saving significant material and carbon costs, thereby achieving a low damage, self-centering structure within the same cost as the original conventional design.

The Outcome

Opening in 2023, the building will set a new standard for low damage design and functional recovery. The design achieved lower embodied carbon and increased usable floor space through removal of two concrete shearwalls.

Design

The lateral system for the Research Building initially included concrete shearwalls and steel concentrically braced frames (CBFs) in the transverse and longitudinal directions, respectively. The primary driver for introducing shearwalls and CBFs was to provide a stiff lateral structure that limited inter-storey drift.

In their quest to deliver new and innovative solutions to clients, Beca introduced Tectonus as an alternative approach during the preliminary design phase, offering advantages of low damage design, zero maintenance, and speed to functional recovery. The client and wider project team agreed to consider the alternative, provided there would be minimal cost increase.

The alternative concept design saw Tectonus RSFJs implemented at the ends of shearwalls and at one end of braces in the CBF direction. The intention was to concentrate energy dissipation at the Tectonus devices and design the remaining building elements and connections for the corresponding building movements to avoid structural damage up to an Ultimate Limit State (ULS) event. The Tectonus devices could also be designed to limit device movements so that inter-storey drifts could remain limited. An added advantage of shearwalls with the Tectonus devices is that large in-plane stiffness of the shearwalls means they act as a stiff backbone and promote movement in the devices.

Engineers conducted push over analysis on the conventional and alternative designs. For the conventional design, ductility came out at 2.0 and lateral drift limit assumed New Zealand Building Code values of up to 2.5%. The alternative design enabled the engineers to control and limit the ULS and SLS drifts to a lower level which enable considerable savings with the omission of deflection head details for non-structural partition walls.

Design Results

Removing two of the eight concrete shear walls reduced material cost, labor and created more space and light. Together with the higher level of seismic resilience, these advantages were greatly appreciated by the architect and client.

The client's requirements had been met and the green light was given to the Tectonus-based alternative design concept. The building was opened to students in 2023.

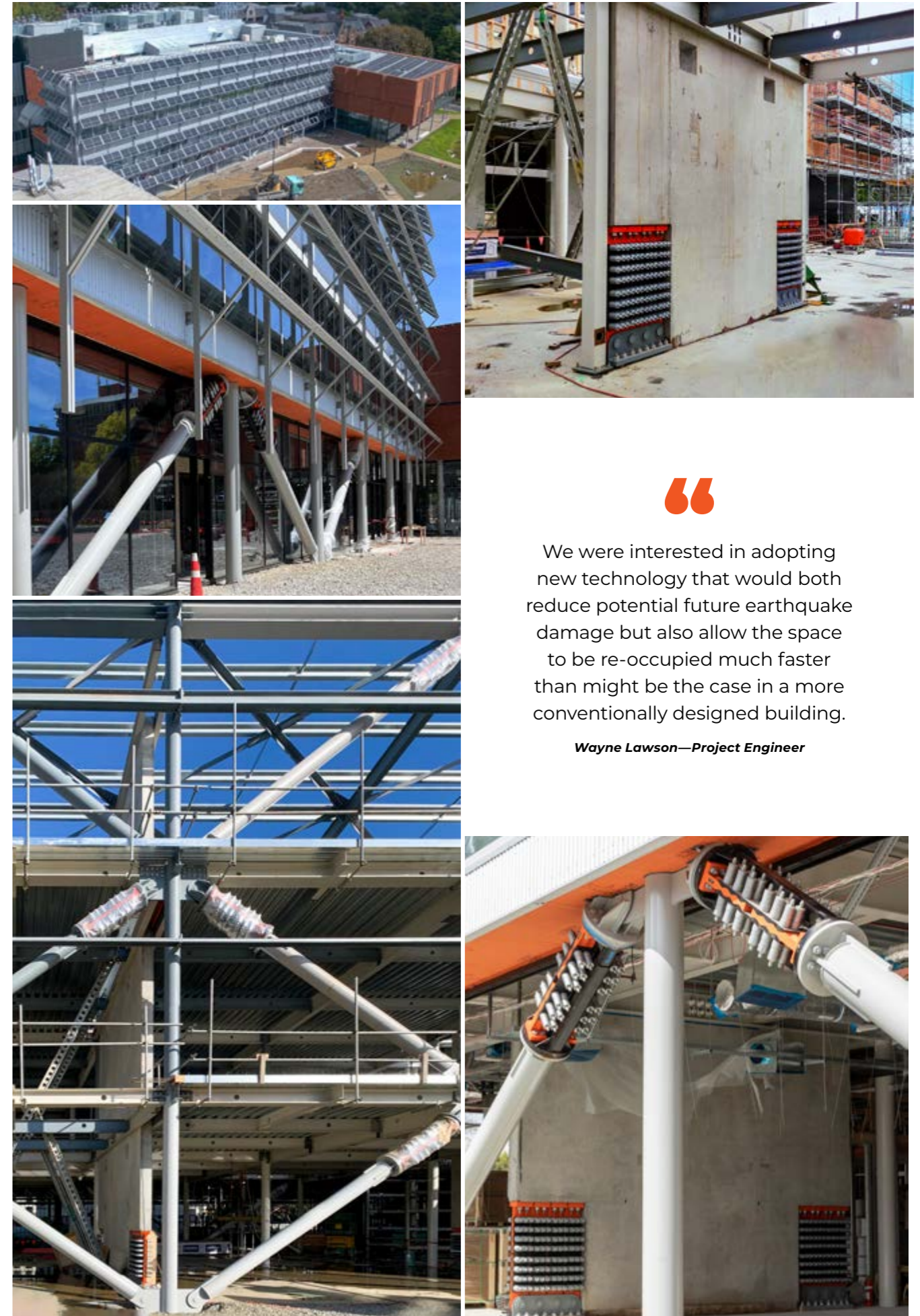

We were interested in adopting new technology that would both reduce potential future earthquake damage but also allow the space to be re-occupied much faster than might be the case in a more conventionally designed building.

Wayne Lawson—Project Engineer

Engineer / Fast+Epp

Architect / DIALOG

Main Contractor / Ventana Contruction

Client / Bental Green Oak

KEITH DRIVE OFFICE BUILDING

Vancouver, Canada

The Challenge

Keith Drive was specified to be a 'pure' mass timber superstructure complete with a timber lateral system. Exposing timber wherever possible was a key goal for client and architect. The 10-storey building required innovative seismic protection.

The Impact

The initial design for the building could not be proven to withstand site specific seismic loads in lab tests. Tectonus devices were proposed, with validated testing, that could allow the all-timber design to go ahead.

The Outcome

With superstructure due to be completed in 2024, the Keith Drive building will be a first-of-its-kind all-timber braced frame building in a high seismic zone.

Design

Keith Drive Office Building project is a 10-storey mass timber building in Vancouver, Canada. The office building includes exposed timber throughout most of the building, including timber brace frames along the perimeter, and cross laminated timber (CLT) shearwalls at the interior near the elevator and stair cores for seismic and wind forces.

The project uses Tectonus devices as energy dissipative devices on both the timber braced frames and CLT shearwalls. Non-linear time history analysis (NLTHA) was completed to evaluate the performance of the building.

The 43 meter tall structure is comprised of nine floors of mass timber construction over a concrete podium and four levels of below-grade concrete parking. The Seismic Force Resisting System (SRFS) consists of perimeter timber braced frames and interior balloon framed CLT shearwalls.

To achieve energy dissipation without damaging the structural members or connections, Tectonus RSFJs will be installed in each brace (one end), and at the ends of the CLT shearwalls, as hold-downs, allowing energy dissipation without damage to the structural system. Maximum brace forces of 1800 kN at the bottom floor and hold-downs of 2700 kN.

An NLTHA was completed, alongside a thorough third-party peer review. Iterative NLTHA was used to optimize the Tectonus devices design for the 2% in 50-year design earthquake.

The maximum design drift achieved was 1%.

Design Results

The innovative timber braced frame and tall CLT shearwall system proposed for this project significantly exceeds prescriptive approaches for timber systems in the NBCC.

With the implementation of self-centering, zero damage dissipative Tectonus devices, this building will achieve a high level of performance and will be a first-of-its-kind timber lateral system in a seismic zone for a tall timber building in North America.



Engineer / Dunning Thornton

Architect / Studio Pacific

Main Contractor / Naylor Love

NELSON AIRPORT

Nelson, New Zealand

The Challenge

The new Nelson Airport brief required creation of an iconic, lofty space that reflected the local landscape and would serve as a “gateway” to the South Island of New Zealand. The design needed to be modular for future expansion and be built from locally sourced timber.

The Impact

During design development Tectonus was introduced as an innovative alternative solution that not only provided the required damping but also self-centers in a compact “plug-and-play” element that enabled the ambitious design.

The Outcome

The Nelson Airport has won multiple awards for its striking architecture and innovative engineering design. It has been admired locally and internationally for use of locally sourced timber, construction approach and seismic design.

Design

The Nelson Airport is situated in one of the most picturesque areas of New Zealand, which welcomes a growing number of tourists. The design of the airport needed to be modular to account for future expansion and was specified to be built from locally sourced materials. The architectural response to this brief was to mirror the local Richmond Ranges, with an undulating timber roof that sits high above the ground.

The building is 3800m² of ground floor space with 1200m² of mezzanine area. The roof consists of 7 repeated bays stretching over 100m. This sits atop highly liquefiable ground in a high seismic hazard zone. The building is Importance Level 3 due to its function as an airport terminal.

The long-span timber roof sits on widely spaced columns, to maximize the open space and glazing. The roof spans 18.6m between columns, and each bay is 15m wide. This presented an engineering challenge to form the roof without visually heavy structure. The roof was designed as a “folded plate” structure.

The seismic demands on the building are relatively high, and the timber structure was tall and flexible with little inherent ductility. Nelson has a medium to high level of seismicity (with a hazard factor of 0.27). The lateral resisting system in the short direction across the building consists of 15 cantilevered LVL columns, staggered along each façade. The longitudinal direction (along the 100m length) consists of a central “moment-resisting frame” formed by

the “diamond” clerestory LVL beams and 7 LVL columns. The diamond beams follow the shape of a traditional beam bending moment diagram. The “moment” is generated through a tension and compression couple in these beams which create a push-pull on the column.

As in most timber structures, ductility was required through an additional damping mechanism. Displacement-based design method was used and verified using non-linear time history analysis. The NLTHA modelled the Tectonus device behaviour and the hinges at the bottom of the reinforced concrete mezzanine columns.

The highest point of the roof is 12m above the ground floor slab, so the timber structure is stiffness governed. Even though the columns are 1220mm by 300mm, which is a full LVL billet, cold-laminated to the maximum thickness, the elastic component of the hysteretic loop is significant. The height of the columns also meant that any additional rotation at the base was amplified. The high initial stiffness of the Tectonus RSFJs before the “slip” point was important to keep the overall drift down. Tectonus devices have a capacity of 350kN in tension-only with 20mm displacement.

Design Results

The use of the Tectonus devices enhanced the seismic performance of the building, making the grand heights of the roof possible while keeping the column sizes proportional and economical to the space. The result is an exquisite building that showcases an aesthetically pleasing facility with added benefits of long-term seismic protection.

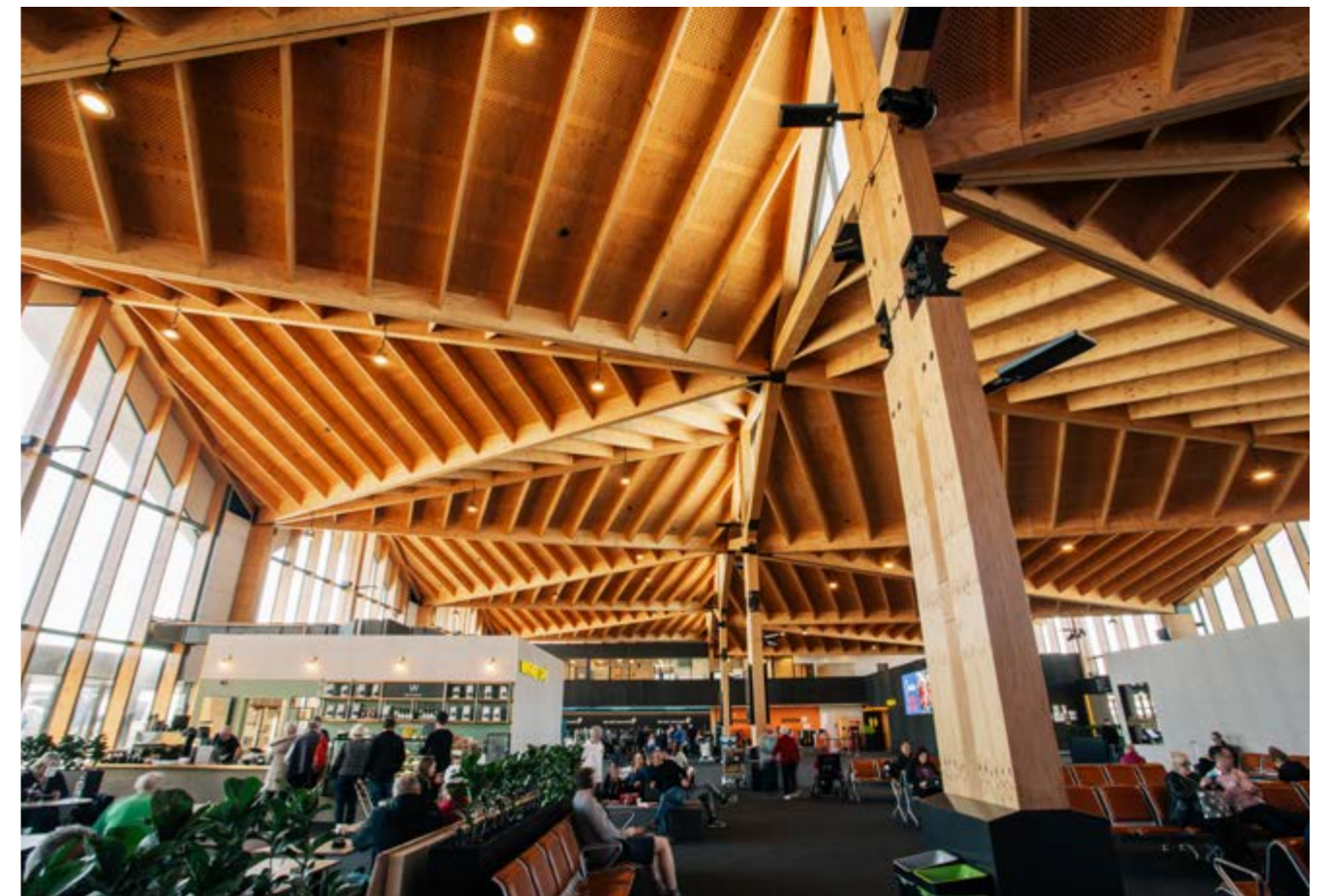

Engineer / Structure Design & Phoenix Consultants Client / Russell Property Group

OXFORD TERRACE

Christchurch, New Zealand

The Challenge

66 Oxford Terrace was an earthquake prone building (NBS of <34%), written off by insurers then acquired by Russell Property Group, with a view to seismically strengthening and refurbishing the high-end apartment building for resale.

The Impact

The proposed seismic solution came in more cost effective than competing approaches with the added benefit of requiring no maintenance even after a seismic event. Saving the building avoided some 500,000 tonnes of carbon emissions if it had been demolished.

The Outcome

Once completed, the building's NBS will be increased to 100% and it will be removed from the Earthquake Prone Building register. Most of the refurbished apartments have been sold off the plans, achieving premium sales prices for Christchurch.

Design

Initially unclear if the building could be saved or if it was more economical to demolish and rebuild, Russell Property Group held a design competition with three separate engineering firms to produce retrofit proposals for the building to achieve a minimum of 100% of the New Building Standard (NBS).

The winning solution, designed by Structure Design in collaboration with Phoenix Consultants, utilized Tectonus devices. The selected retrofitting scheme was to convert the existing concrete walls to controlled rocking walls. Focusing the seismic deformations to the horizontal rocking plane at the base of the tower reduces the seismic deformation and force demands on the existing elements of the tower. This reduces significant seismic strengthening to only the lower levels of the primary shearwalls and secondary walls and reduces the degree of strengthening required to upper-level diaphragms.

This has two main advantages. Firstly, the construction work was limited to the bottom of the structure, and secondly, the combination of rocking/damping reduced the seismic demand in a way that the target %NBS can be achieved at relatively lower inter-storey drift (about 0.7%).

To assist with the detailed design and analysis, a site-specific hazard analysis was undertaken by Bradley Seismic Ltd, so that site-specific earthquake spectra could be used rather than what are generally more conservative design loadings code.

Thirty Tectonus devices (a mix of RSFJs and DFFJs) are installed at the base of the concrete walls (above the podium). The connectors add the required level of energy dissipation to the building while ensuring the building

can withstand the design level earthquake with minimum damage. In fact, the over-strength mechanism developed for these devices allows the building to tolerate seismic events much larger than the design level earthquake. As an added advantage, the building will also be able to self-center, an intrinsic benefit of the Tectonus connectors.

Primary non-linear static pushover analysis showed that the resilient devices would increase the hysteretic damping of the tower to an average of 7.5%, equating to an average ULS ductility of 1.73 with a structural performance factor of 0.7.

Engineers performed a secondary analysis to validate the primary analysis method. Non-linear dynamic time history analysis used a suite of site-specific time history earthquake records provided by Bradley Seismic. This showed that the dynamic magnification of shear forces is only found to be significant at the lower levels of the tower, which are subsequently designed for the magnified higher shear forces. The added stiffness and damping of the resilient devices help to mitigate the dynamic impact at the base of the rocking walls, which are further armored with steel plates. The resilient devices provide sufficient self-centering to mitigate potential ratcheting with no residual drifts.

Design Results

The final design was more cost effective than other more traditional strengthening options. It kept the building within the footprint which was a key requirement of the local council and it localised major structural works largely to the basement and first two levels, meaning no unsightly visual elements or space reduction in the higher-value upper-level apartments. Additionally, apartment refurbishment work could proceed in parallel with structural works, reducing the construction programme and time to re-occupation.

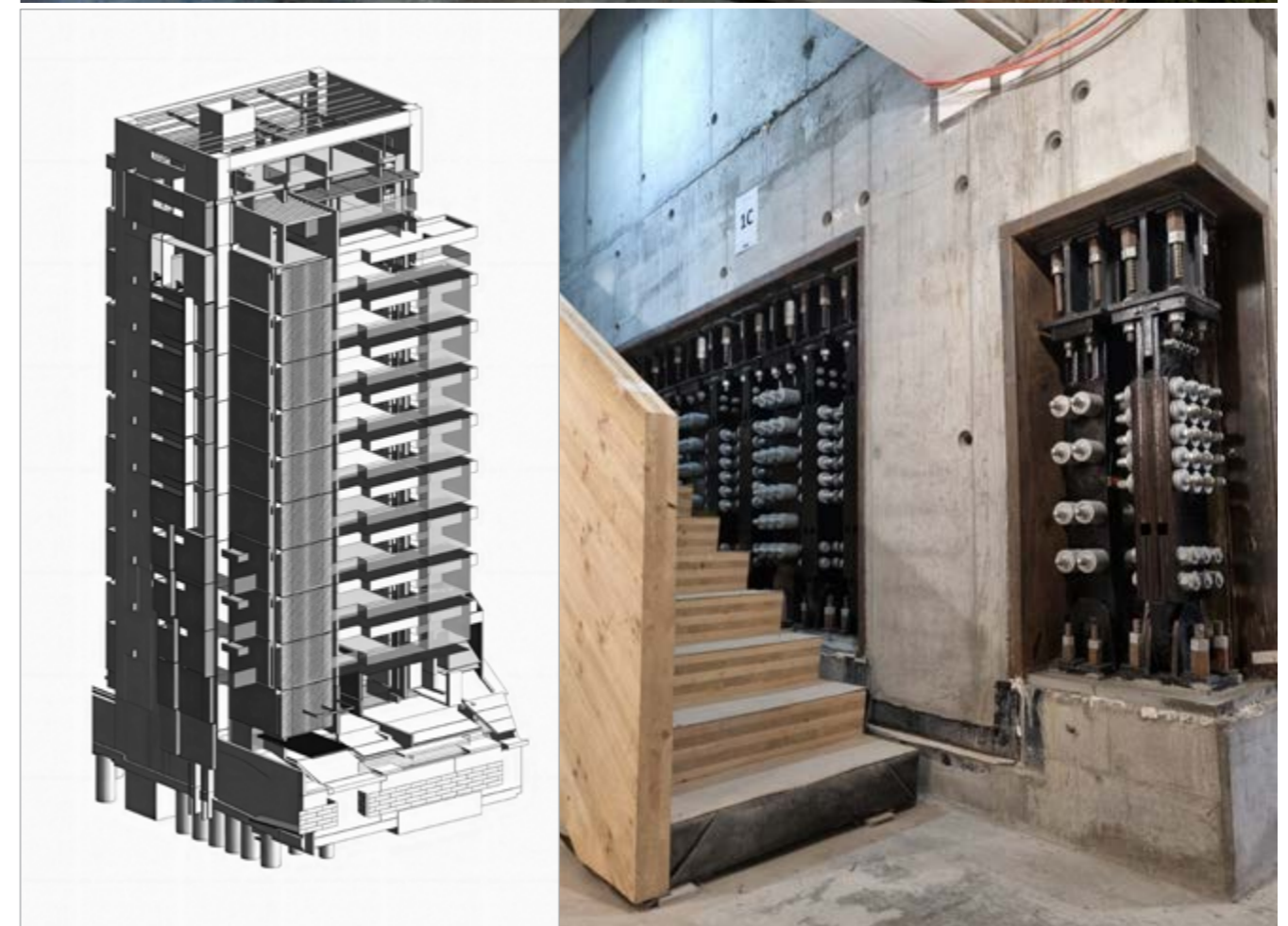

Engineer / RJC Engineers

Architect / Iredale Architecture

TSAWWASSEN FIRST NATION ELDERS CENTRE

Tsawwassen, Canada

The Challenge

Tsawwassen First Nation Elders Centre needed a cost effective way to meet Canada's Post-Disaster building standard whilst retaining key cultural aspects of the architect's vision.

The Impact

Incorporating Tectonus technology reduced the design demand force in the LFRS by approximately 20%, compared to a conventional system that would have required increased capacity to limit GILD below the code requirement.

The Outcome

The community's Elders have a new home which reflects their cultural values and offers long term security. The self centering design means structural damage and downtime will be limited, should a future earthquake strike.

Design

The First Nation Elders Centre, located at the Blue Heron Way precinct in Tsawwassen, BC, represents a commitment to seismic resilience, sustainability and cultural values. This two-storey steel structure, with its elegant glulam roof, has been designed to withstand post-disaster earthquake forces. Encompassing approximately 10,000 square feet, the building serves as a crucial hub for the Tsawwassen First Nations community, integrating their rich history, culture, and symbolism into its design.

The design team faced the challenge of adhering to stringent post-disaster performance criteria, necessitating a robust and innovative approach to the building's lateral force-resisting system (LFRS).

According to the British Columbia Building Code, post-disaster buildings are designed to remain operational and safe for occupancy immediately after a seismic event. This means they must be designed to withstand stronger ground shaking and more stringent performance criteria.

One of the primary design challenges stemmed from the architectural vision of incorporating sloped columns. While aesthetically pleasing, these columns introduced a Gravity Induced Lateral Demand (GILD) irregularity, which is typically prohibited for post-disaster buildings due to the increased lateral forces they generate. The client's requirement for post-disaster performance necessitated a solution that could overcome this irregularity without compromising the building's structural integrity.

After reviewing the options, the design team chose Tectonus self centering dampers (RSFJ). The LFRS for the Elders Centre comprises steel braces in series with Tectonus devices and rocking columns equipped with Tectonus dampers at each end.

Design Results

The Tectonus RSFJ self-centering friction damper emerged as the ideal solution. Known for its self-centering behaviour, the Tectonus device has the unique capability to restore the building's plumbness after an earthquake event. This feature is particularly advantageous for post-disaster buildings, where immediate functionality and safety are paramount. It is also much more compact and cost-effective than other options for achieving self centering such as base isolation, and viscous dampers or BRBs coupled with a moment frame.

The incorporation of Tectonus technology significantly reduced the design demand force in the LFRS by approximately 20%, compared to a conventional system that would have required increased capacity to limit GILD below the code requirement. This enabled the distinctive sloped roof design and compliance with the stringent post disaster standard more cost effectively than other options considered.



Engineer / CGW Consulting Engineers

Developer & Architect / MediSpace NZ

Owner / Vital Healthcare Property

HUTT VALLEY HEALTH HUB

Lower Hutt, New Zealand

The Challenge

The building was specified as an IL4 (importance level 4 building) from the outset. Directly beside the hospital, the hub would house integrated medical care for the community. This IL4 specification mandated high seismic resilience.

The Impact

With Tectonus devices, the building would be considered one of the most resilient in the seismic prone area. Designed to be fully operational following a major seismic event, it became home to a suite of specialist community and medical care providers.

The Outcome

The purpose-built community facility was designed to a high level of seismic resilience (greater than 100% of current building code). The building was acquired by Vital Healthcare Property who operate a portfolio of healthcare facilities.

Design

The seismic design procedure chosen for the lateral system of the building was a mix of the Equivalent Static Method (ESM) and Nonlinear Static Pushover Analysis (NLSPA). The first mode dominant nature of the building and the regular layout of the lateral structural system made NLSPA the logical choice for verifying the building's seismic performance. The building owner was particularly concerned about damage to drift sensitive components within the building, so target drift levels for the SLS1, SLS2, ULS, and MCE limit states were discussed and set early in the design process.

Preliminary sizing of the lateral system and the Tectonus devices was completed by utilising a mix of hand calculations, linear-elastic models of the buildings, and the Equivalent Static Method. Equivalent static forces we derived for a ductility of 2.0, conservatively chosen (with guidance from Tectonus) to represent realistically achievable levels of damping due to the flag-shaped hysteretic behavior of the Tectonus devices.

On completion of the preliminary design, required force-deformation data was given to Tectonus to design their devices. After finalising their design, the hysteretic data for each device was provided, meaning the devices could easily be added to the structural model of the building, allowing the creation of a non-linear structural model. Once the non-linear structural model had been developed, multiple NLSPA cases were run. Resulting pushover curves

were exported and combined with Horizontal Acceleration Displacement Response Spectra (ADRS) derived from NZS 1170,5:2004 (New Zealand Standards, 2004). The resulting charts were used to verify the seismic performance of the building. ADRS curves were developed for the SLS1, SLS2, ULS, and MCE limit states, allowing simple performance checks by comparing actual and target drifts. To produce the ADRS plots and overlay the pushover curves, guidance was taken from The Seismic Assessment of Existing Buildings, Sections C2 and C3 (2017). Once the seismic performance of the building and the Tectonus devices had been verified, capacity design principles were applied to design the remainder of the lateral system by considering the overstrength behaviour of the devices.

Design Results

Tectonus RSFJs can be seen in the braces and shearwalls of the building. The devices were installed in parallel to increase capacity whilst maintaining ease of installation with smaller devices.

The shearwall hold downs have a capacity ranging from 1,220kN to 2,050kN. The brace capacity ranged between 300kN to 600kN.

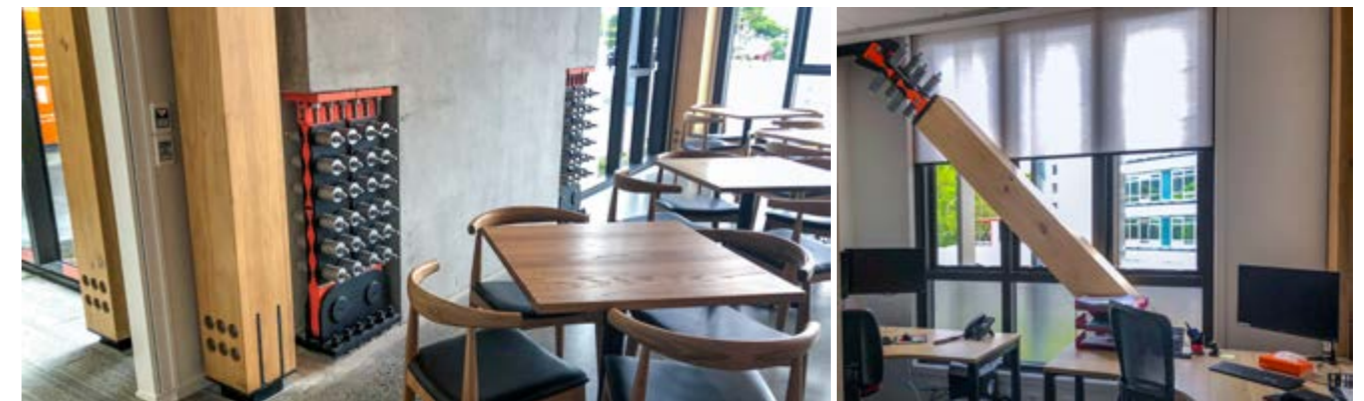

Engineer / Fast+Epp

Architect / f2a architecture

Main Contractor / Seagate Mass Timber

FAST+EPP HEAD OFFICE

Vancouver, Canada

The Challenge

Known for their holistic designs and award-winning projects, Fast+Epp wanted their own new office building to showcase innovative technologies and resilient design.

The Impact

Tectonus devices allow the CLT shearwalls to effectively decrease seismic demand on the structure and provide continuous self-centering to the building.

The Outcome

The building is a beautiful exemplar of elegant and functional design. The self-centering behavior of the building will reduce residual drift and enable Fast+Epp to recover quickly following a future earthquake.

Design

Fast+Epp is globally recognized for their engineering design work in high profile projects such as the 3 million square foot Walmart Home Office campus in Bentonville, Arkansas and 10-storey Arbour at George Brown College. With an ambitious desire to push the design envelope on projects, it was incumbent on Fast+Epp to walk the talk when presented with the challenge of designing their own office space.

The new head office is a multi-storey building including several floors of offices and a living lab on the ground floor, all levels beautifully showcasing timber structural elements. Large windows make use of natural light and enhance the open concept spaces. The lateral design of the four-storey structure utilizes Tectonus devices installed at the base of CLT shearwalls, seamlessly fitting into the building aesthetic.

Three methods of analysis were used as part of the design, including the Equivalent Static Analysis (Linear static), the Response Spectrum Analysis (linear dynamic), and the Pushover analysis (non-linear static). More detailed lateral analysis models were created in ETABS for response spectrum and pushover analyses. CLT wall behavior and material/section properties in ETABS were calibrated to equivalent deformation and properties using RF-Laminate in RFEM.

The base of the narrow CLT shearwalls was modelled using a shear only connection at the panel center (reflecting the actual design detail of a concrete shear lug in this location) with spring elements at either end representing the Tectonus devices.

Ultimate hold-down forces determined from the response spectrum model along with allowable rocking displacement of the CLT walls were provided to Tectonus engineers, to calculate the device properties. Tectonus provided key values of the flag-shaped hysteresis to define the non-linear springs of the pushover analysis. The pushover analysis was carried out in the across direction only and used to validate the load distribution, the tension in each device and the displacement of the walls.

Design Results

Tectonus RSFJs were installed at the base of the rocking CLT shearwalls. The connection to the CLT consisted of knife plates and 35-16mm dowels. Each Tectonus device has a capacity of 700kN. The bottom connection consists of a 80mm pin into a swivel bearing allowing for +/- 5% out of plane drift. The devices fit seamlessly with the shearwall and are left exposed to showcase the innovative devices within the building.

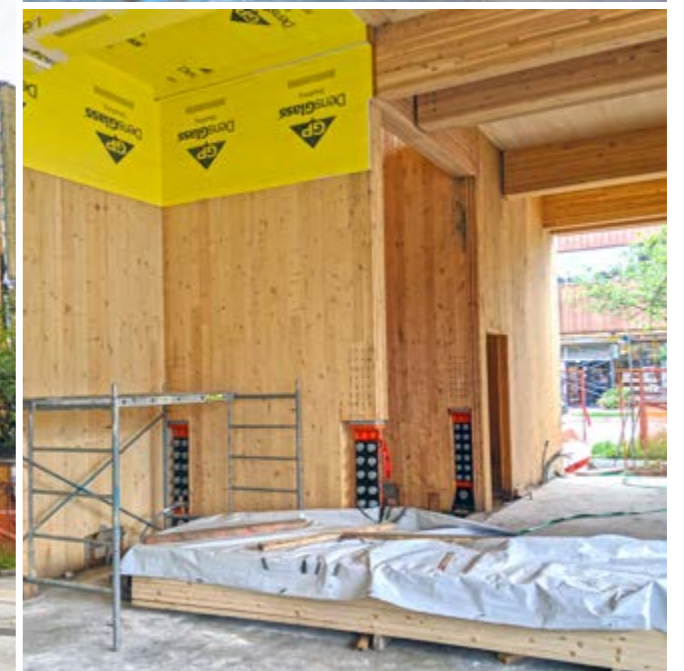

Engineer / TEKTON Consulting Engineers

Main Contractor / Cape Interiors & Construction

48 GREYS AVE

Auckland, New Zealand

The Challenge

Though Auckland is relatively low seismic risk, the addition of a new floor 40m above ground could result in significant accelerations in a seismic event.

The Impact

The engineer chose to combine the popular ReidBrace cross-bracing system with Tectonus devices which increased seismic capacity by 300%.

The Outcome

The combined system is cost effective, lightweight and easy to install, and minimized use of additional structural materials.

Design

48 Greys Ave is an existing 10-storey concrete office building in central Auckland undergoing a major refurbishment that will see the addition of a new 900 square meter upper level.

Although the seismic risk at this site is relatively low, the addition of the new floor, 40 meters above ground, meant that it could experience some very high accelerations in a significant seismic event.

Proposing a lightweight steel frame structure, TEKTON Consulting Engineers wanted to avoid heavy steel bracing and unnecessary additional loads and inertia forces on the existing concrete structure below.

ReidBrace is an off-the-shelf system that utilizes threaded rods arranged as tension members. The system is lightweight and easy to install with minimum extra processes onsite. However, ReidBrace by itself could not provide the level of damping required.

Design Results

This led them to combine ReidBrace cross bracing with Tectonus tension-only RSFJs. The combination delivered sufficient damping at a high global ductility, removing the need for any additional members or strengthening to the existing structure.

The project led Ramset and Tectonus to collaborate on the launch of a new product called ReidBrace Xtrem, so more engineers can utilize this unique combination of high ductility in a lightweight and cost effective package.

"We found Tectonus very knowledgeable and supportive throughout the process. These guys are easy to collaborate with, and they talk the same "seismic expert" language with TEKTON" – Ioannis Prionas, CEO TEKTON Consulting Engineers.

Featuring:

ReidBrace™ Xtrem™

Powered by Tectonus™

In partnership with Ramset we've launched the ReidBrace Xtrem which is a cost effective cross-bracing system with 3X higher ductility suitable for new and retrofit single storey and low rise multi-storey buildings. By reducing seismic demand ReidBrace Xtrem lowers the cost of seismic compliance by enabling savings in structural materials and foundations.

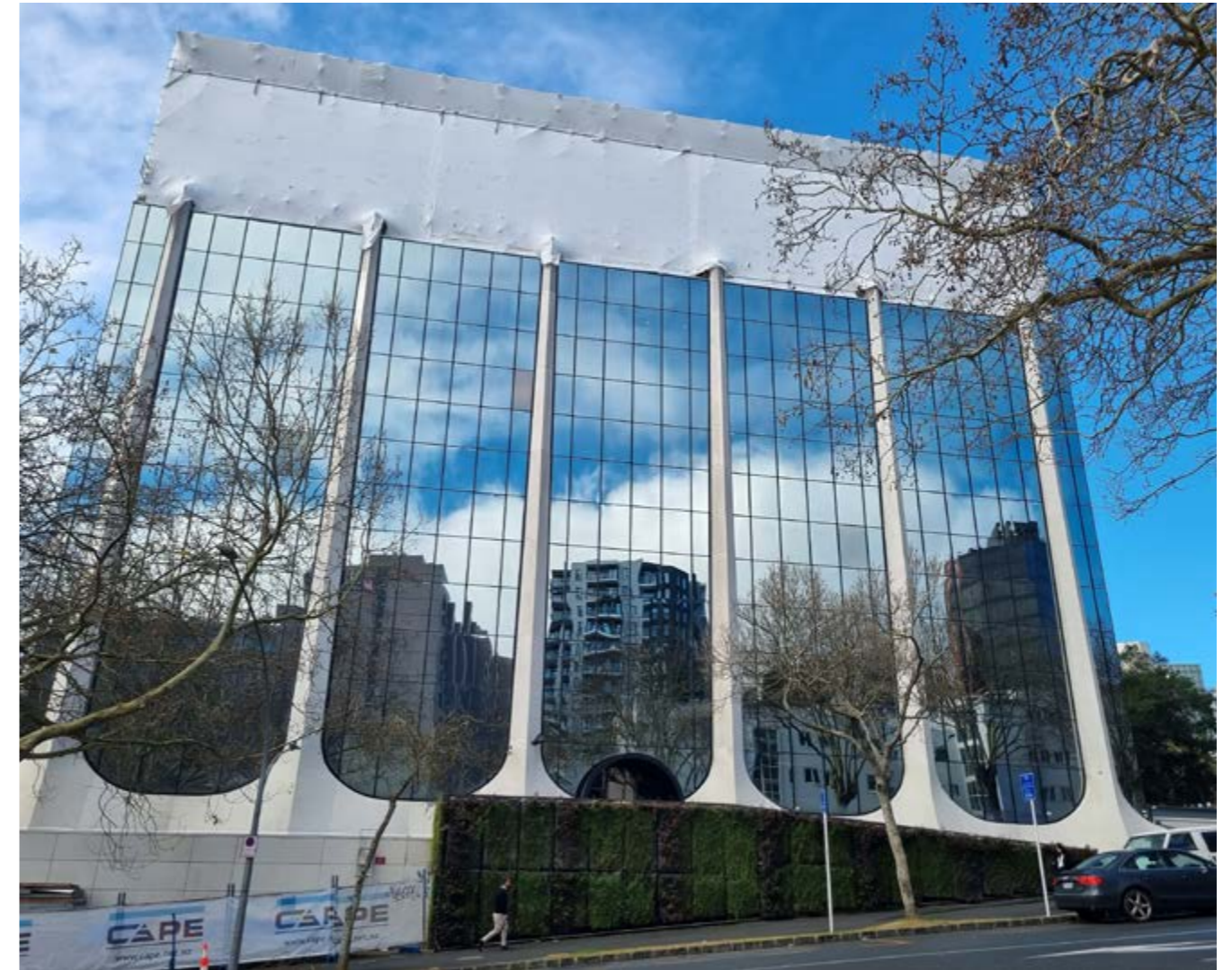

Engineer / WSP (Opus) NZ

Main Contractor / Hanham Phillip

CHRISTCHURCH CATHEDRAL COLLEGE

Christchurch, New Zealand

The Challenge

Christchurch College required a new multi-storey classroom and administration building block that prioritized resilience and sustainability whilst meeting their allocated budget.

The Impact

The Tectonus devices ensured the building met the low damage system objective. Incorporating Tectonus devices also aided efficient on-site construction timeframes and lowered the carbon footprint of the project.

The Outcome

The mass timber building successfully used full height CLT panels with Tectonus devices installed as shearwall hold-downs and enabled an accelerated construction timeframe. The client was pleased with overall budget and the long-term seismic protection to the structure.

Design

The new building for Christchurch's Cathedral College is a three-storey classroom and administration block with a 1,500m² gross floor area. The ground floor level includes offices and staff areas, while the upper two levels include classrooms and collaboration spaces. The building is situated in the central area of the city and was specified to have high resilience from the outset.

The building comprises full height rocking Cross Laminated Timber (CLT) shearwalls with CLT suspended floors, on a shallow concrete foundation.

The client specified a high resilience system from the beginning of project planning. WSP design engineers utilized their in-house 'Future Ready' approach which follows international best practices for projects to achieve meaningful and sustainable outcomes. Tectonus was proposed as the best suited option that would achieve the specified brief with long-term seismic protection.

Non Linear Static Analysis was used by the WSP design engineers to assess building performance and validate requirements of the Tectonus devices. The devices provided a lightweight seismic protection solution that would easily be installed to the shearwalls.

The use of full height CLT panels resulted in an accelerated construction timeframe. The primary structure higher seismic resilience exceeded the New Zealand Building Code minimum requirements. The mass timber construction also realized sustainable benefits through reduced carbon emissions.

Design Results

The size and performance specifications of the Tectonus RSFJs meant a straightforward and relatively simple build of the multi-storey structure. The building resilience performance was appreciated by the client.

The lightweight solution and panelized system enabled an efficient construction programme timeframe with additional cost savings. In addition, the primary structure realized higher seismic resilience and exceeded the New Zealand Building Code minimum requirements.

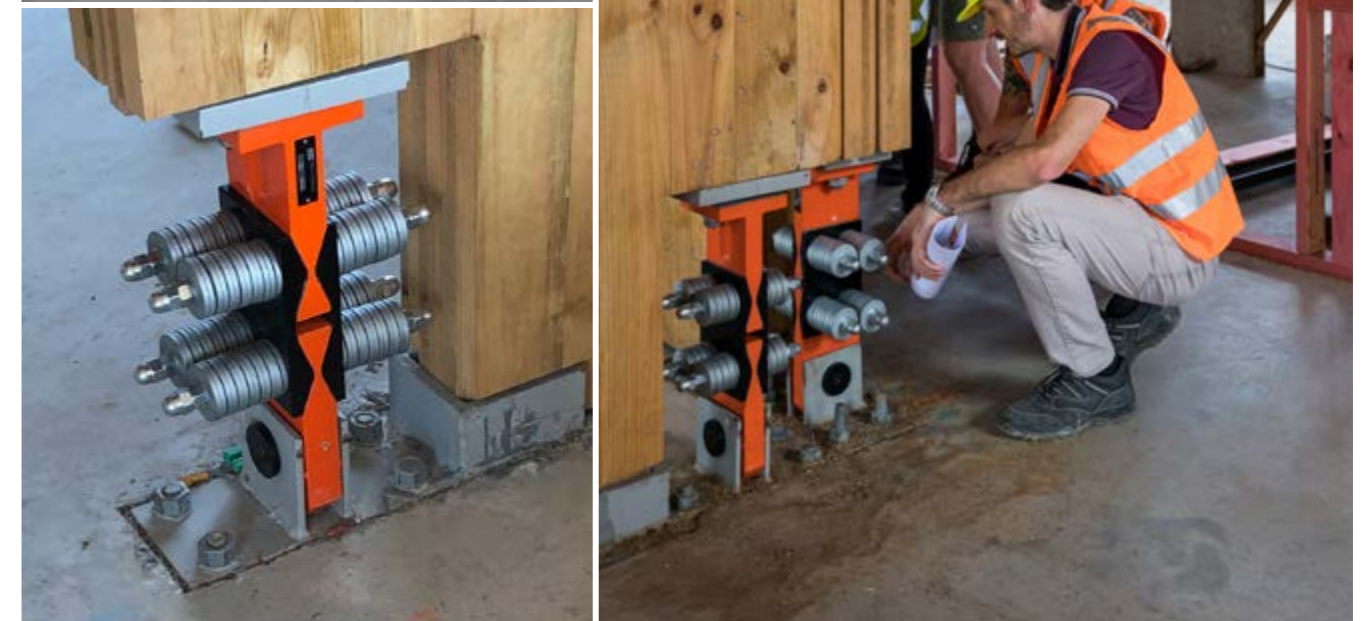
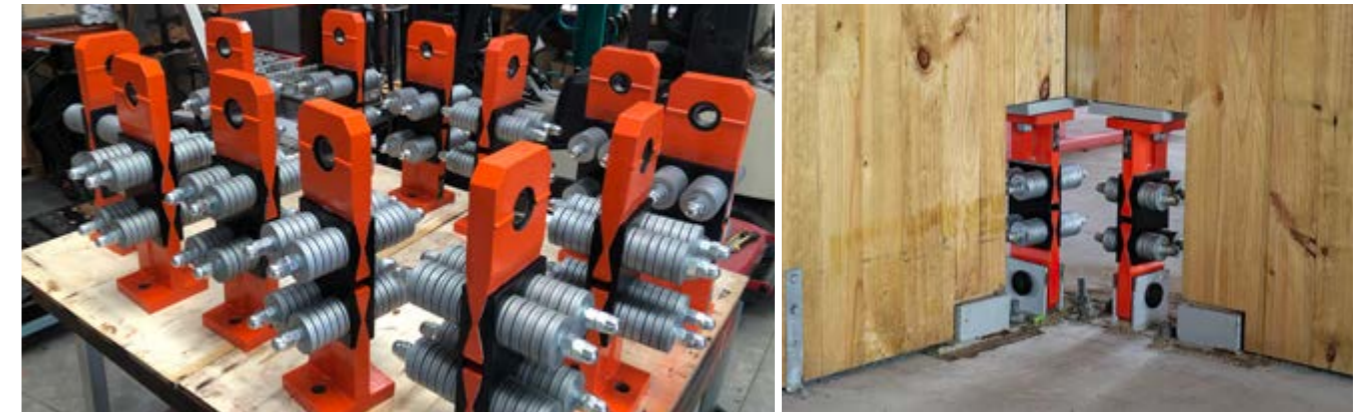

Specialty Engineer / Timber Engineering Inc
Structural Engineer / Equilibrium Consulting Inc

Architect / Hemsworth Architecture Inc
Main Contractor / Naikoon Contracting Ltd

oN5 OFFICE BUILDING

Vancouver, Canada

The Challenge

The Timber Engineering Inc team was challenged to push the limits of mass timber structural design when designing their new home office on a mid-block site with 7.6m wide street front.

The Impact

Tectonus devices were selected to provide seismic resilience and complement the CLT structural system in an innovative, “drop-in” configuration that achieved a tightly planned construction schedule within the tight city lot.

The Outcome

oN5 serves as a successful demonstration project that showcases innovative design and build of high-performance mass timber structure, with high resilience and efficient onsite construction.

Design

Named for its location near the intersection on Ontario Street and East 5th Avenue in Vancouver, Canada, oN5 is an innovative four-storey building designed and constructed to showcase the potential for commercial mass timber. The building is the new home for Timber Engineering Inc., an engineering firm with a worldwide reputation for its advanced timber engineering expertise.

oN5 was designed to Passive House principles, one of the most rigorous voluntary energy-based standards in the design and construction industry today.

The main lateral load resisting system is comprised of a rocking CLT core equipped with Tectonus devices used as hold-downs. This, in concert with the steel moment frames at the North and South ends of the building, formed the major elements of the lateral structural system.

The Direct Displacement Based Design (DDBD) procedure was used to specify the Tectonus devices. Using this procedure, the structure is represented as an elastic Single Degree of Freedom structure (SDOF) with effective stiffness and effective period to predict the inelastic response. The pushover curves are generated for the structure using the two critical load patterns.

The demand was established by the Canadian code with a probability of exceedance of 2% in 50 years (1/2500). In plan,

the building is approximately 7.6m wide and 36m long. The 3-storey CLT structure sits on a concrete podium. Timber CLT walls and floors make up the gravity system with X direction LLRS including a rocking timber elevator core and Y direction LLRS as elastic CLT long walls. The maximum design drift achieved was 1.5%.

Non Linear Static Analysis was performed on the structure. The structure achieved 15% damping and was fully self-centering.

Implementing the Tectonus RSFJs enabled a rocking core mechanism with achieved ductility reduction factors of $R_d=3; R_o=1.2$. This resulted in significant reduction in the base shear.

Design Results

oN5 is a fully resilient structure with a rocking CLT core and limited lateral drift which is critical in a tight city lot. The office building typology demonstrates a successful approach for cities and developers to enable building on urban in-fill lots.

This office building combines high performance, mass timber construction, new approaches to insulative CLT assemblies and damage-resistant seismic design. As a demonstration building project, oN5 contributes to the advancements of emerging mass timber construction.

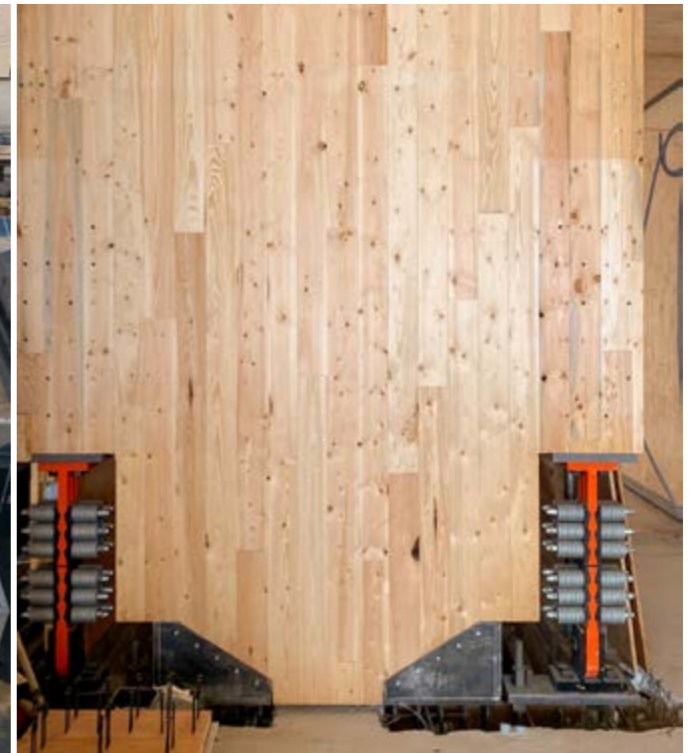
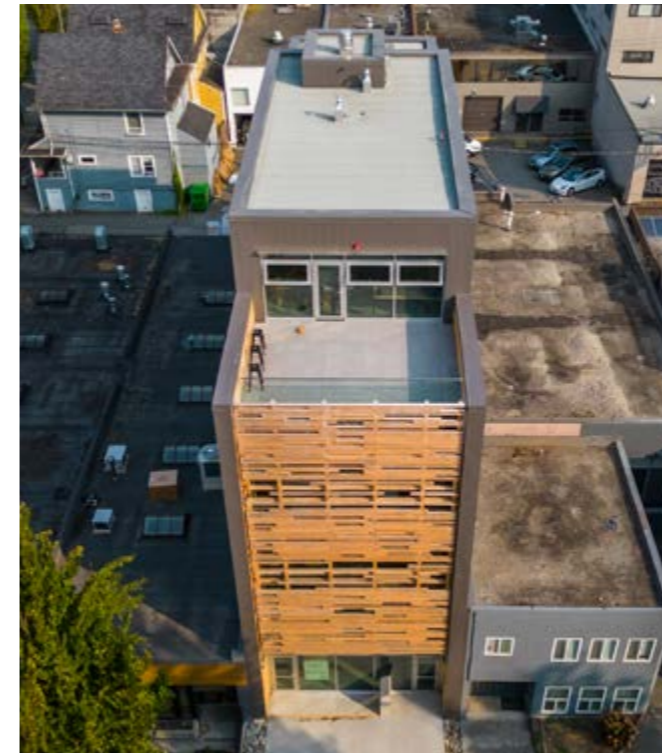

Engineer / John Klimenko

Main Contractor / Robinson Building

TAWA CHURCH

Wellington, New Zealand

The Challenge

Founded in 1952, Tawa Baptist Church has been a landmark in the surrounding community. Sitting on a seismically active zone and marked with low NBS score, the building required cost effective and minimally disruptive seismic retrofitting.

The Impact

The initially design involved adding structural walls and components to the building. With the Tectonus devices, no additional structural elements were required and additional cost saving was able to be achieved.

The Outcome

The building was brought up to 100% NBS with fast and simple installation of Tectonus devices. Installation was executed within one week. The overall project cost was reduced to half of the initial budgeted amount.

Design

Tawa Church is a single-story steel portal frame structure with masonry infills. The client wanted to retrofit the building with the least costly and disruptive method whilst increasing the New Building Standard (NBS) to 100%. With the Tectonus devices in a tension only application, there was no need to add additional walls to the structure as required in the alternative approach..

- Non Linear Static Analysis was completed for this structure.
- Installing braces added damping to the system while enabling the structure to develop about 1% drift.
- The presence of 3 pins in each brace prevents the occurrence of buckling when the direction of the movement shortens the brace.

Design Results

The retrofit was completed in less than a week with no disruption to building operations. The Tectonus tension-only RSFJs are rated for 110kN forces with stainless steel rods giving a very high-quality finish.

The devices were also fitted with mechanical gauges which will show the device capacity used following an earthquake event. Visual inspection is easy as the devices are left uncovered.



UPCOMING PROJECTS

AGRESEARCH

- **Location:** New Zealand
- **Building Type:** Multi-storey Education Building
- **Material:** Mass Timber
- **Tectonus Application:** Shearwall hold-downs
- **Status:** Construction completed in 2023



COMMERCIAL OFFICE BUILDING

- **Location:** New Zealand
- **Building Type:** Multi-storey Office Building
- **Material:** Mass Timber
- **Tectonus Application:** Timber braced frames
- **Status:** In Construction



AGED CARE FACILITY

- **Location:** New Zealand
- **Building Type:** Multi-storey Apartment Building
- **Material:** Mass Timber
- **Tectonus Application:** Mass timber rocking wall hold-downs
- **Status:** In Construction



WAREHOUSE RETROFIT

- **Location:** New Zealand
- **Building Type:** Commercial Building
- **Material:** Steel Frame
- **Tectonus Application:** Steel braces
- **Status:** Construction completed 2023

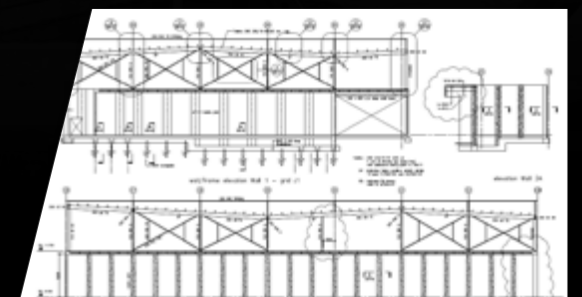



RETROFIT



The Oxford

Moderately ductile concrete shearwall building converted to rocking shearwalls with Tectonus devices. pg 20

RETROFIT

Seismic retrofit of existing buildings presents the ultimate challenge for the structural designer.

Tectonus devices concentrate damping and self-centering (if required) in discrete locations. This results in a retrofit program that is cost effective, minimally invasive, preserves space and the building aesthetic and minimizes downtime for occupants.

STRENGTHENING AND DAMPING

Conventional strengthening increases building members or adds a steel frame to provide stiffness. Sometimes connections and foundations may need to be upgraded to deal with increased seismic demand.

Damping aims to increase ductility thereby reducing seismic demand. For certain retrofit projects this can have real advantages:

- Members can be left as they are
- Connections can be left as they are
- Foundations do not need to be upgraded

TECTONUS SOLUTIONS

Tectonus concentrates dampening and self centering in the devices itself – without need for an additional system e.g. moment frame. The result is a retrofit solution that leaves large parts of the structure untouched.

- Preserve usable floor space
- Maintain the building aesthetic
- Minimize downtime for the occupants
- Lower total cost of retrofit program.



Tawa Church – Retrofit with Braces

Tectonus device with Mechanical Gauge fitted in a Tension-Only application in retrofit of Tawa Church. pg 27



Braced Frames

Braces made of structural steel sections can work effectively both in tension and compression. Braced frames provide high stiffness and are often used for large lateral loads.

Tectonus devices can be fitted onto the end of existing braces to reduce the demand in braced frames by providing damping.

Advantages

- Brace replacement not required following seismic events
- Ductility of the structure will increase significantly
- No residual drift
- Yielding of the original elasticity design system is eliminated
- The added ductility to the system will result in a reduction of the seismic load
- May reduce need for strengthening other members, connections or foundations
- May reduce labor on site

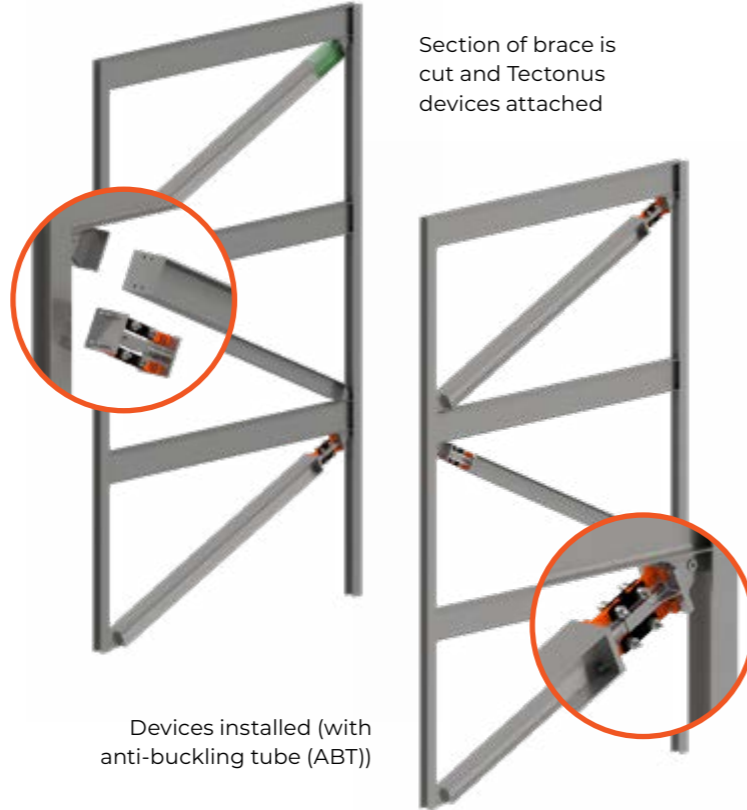

Section of brace is cut and Tectonus devices attached

Devices installed (with anti-buckling tube (ABT))

Rocking Shearwalls and Columns

Conventional shearwalls in earthquake prone structures can be retrofitted by disconnecting the wall from the base and adding devices at the corners. The result is an efficient rocking shearwall with high energy dissipation.

Another option is to affix devices to the sides of the shearwall through corbels.

By using Tectonus devices, high ductility can be achieved for the structure in addition to significantly reducing damage due to yielding.

Advantages

- Ductility of the structure increases
- No residual drift
- No yielding of devices
- No post event maintenance
- The added ductility to the system results in a reduction of the seismic load

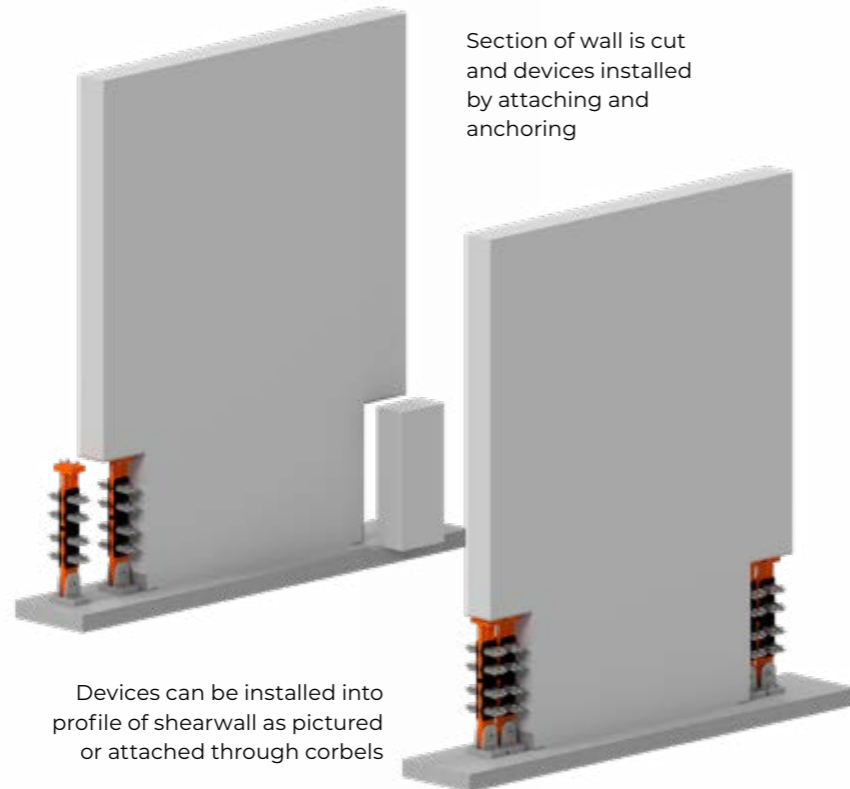

Section of wall is cut and devices installed by attaching and anchoring

Devices can be installed into profile of shearwall as pictured or attached through corbels

Tension-Only Braces

Braces in a tension-only braced frame are commonly rods or bars designed to resist tension. Since the resistance of the braces acting in compression is ignored in the design, tension-only braced systems must be direct-acting and concentrically framed. This type of brace is common in warehouses, non-ductile and structures with limited ductility.

Advantages

- Ductility of the structure will increase significantly
- Yielding of the original elasticity design system is eliminated
- Rod or bar yielding is eliminated
- No pinching effect as there is no yielding
- The added ductility to the system will result in a reduction of the seismic load
- Other members and foundations may not need to be strengthened
- Aesthetically sleek
- Easy to install
- Minimum construction and retrofit work

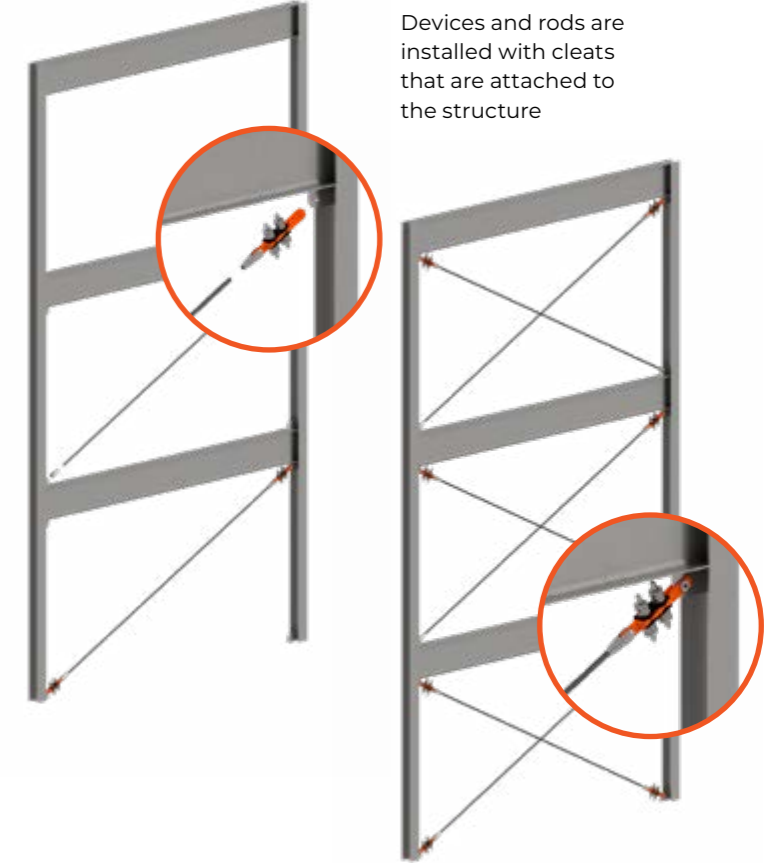

Devices and rods are installed with cleats that are attached to the structure

Moment Resisting Frames

Moment Resisting Frames (MRF) in earthquake prone structures can be retrofitted by attaching brackets and devices to strengthen the MRF and provide additional damping.

This solution can provide resistance to aftershocks which are a significant threat to structural integrity. MRFs crack and soften during seismic events which creates significant collapse risk.

Advantages

- Reduced soft storey effect
- Reduced drift
- Damping and ductility of the structure increases
- No residual drift
- Open space remains between frame



Brackets and devices are attached to the existing frame



DESIGN GUIDE – RSFJ

PRODUCT GUIDE

Device Capacity

Tectonus units can be designed to meet any targeted capacity and deflection. The standard range units can also be applied in multiples in a modular pattern to achieve larger capacities.

Refer to product table on pg 43

Structural Modelling & Design

Refer to the Structural Modelling Guide for the recommended design procedure pg 45. An example is shown in the guide that illustrates best practice. The in-house engineering team offers tailored support at every step of the project

Applications & Dimensions

Tectonus device dimensions are a guide for

BRACE

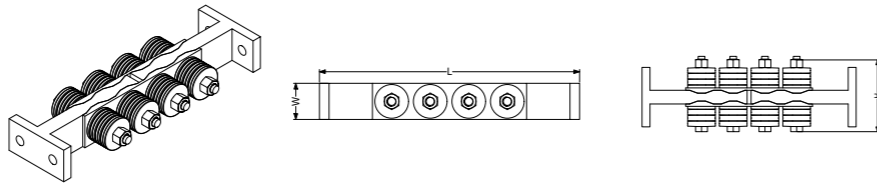

SHEARWALL

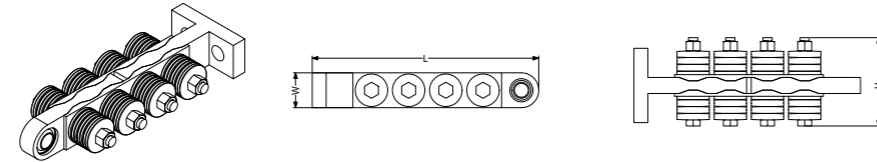

TENSION ONLY BRACE

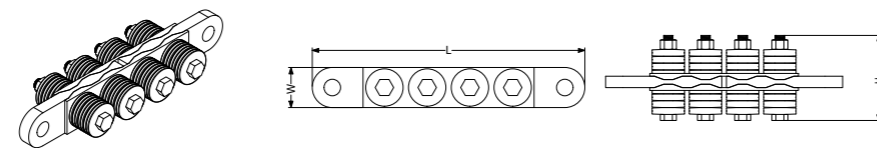

MOMENT RESISTING FRAME

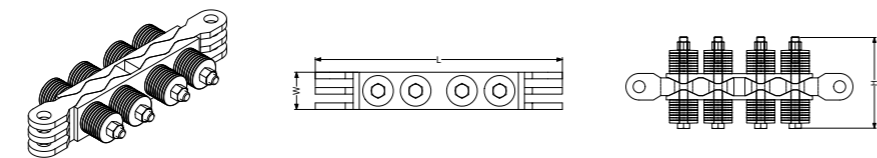

Dimensions

The dimensions of the Tectonus devices depend on the demand deflection.

To support the application of device in a wide range of brace sizes, the units are provided up to 4 different range of deflections.

NO. OF BOLTS	L (mm)	W (mm)	H [mm]
2	refer to table on pg 40	80	2.83 Δ_{ult} + 100
4		80	
6		160	
8		160	
16		240	
18		240	

Configuration Options

Tectonus device capacity options are listed in the product table on page 43.

Some capacities can be designed in more than one configuration giving engineers design options that can be beneficial for space constraints and ease of installation.

SINGLE

Device has single row of bolts



DOUBLE

Device has 2 rows of bolts



TRIPLE

Device has 3 rows of bolts



FOR BRACES

The Tectonus devices in brace applications are installed with anti-buckling tubes.



DEVICES INSTALLED IN PARALLEL

Multiple Tectonus devices can be installed in parallel in order to achieve higher capacity demands.





APPROXIMATE LENGTH			Δ_{ULT} (mm)	APPROX. CAPACITY F_{ULT} (kN)	UNIT CONFIGURATION OPTIONS		APPLICATION				APPROX. CAPACITY F_{ULT} (kips)	Δ_{ULT} (inch)	APPROXIMATE LENGTH		
SINGLE ROW (mm)	DOUBLE ROW (mm)	TRIPLE ROW (mm)			Rows Note: pic on side for purposes of this table	Brace	Shearwall	X-Brace	MRF	"SINGLE ROW (inch)"			"DOUBLE ROW (inch)"	"TRIPLE ROW (inch)"	
550	--	--	25 to 50	50	Single 	✓	✓	✓	✓	10	1 to 2	22	--	--	
550	--	--	25 to 50	75		✓	✓	✓	✓	15	1 to 2	22	--	--	
550	--	--	25 to 50	100		✓	✓	✓	✓	20	1 to 2	22	--	--	
700	550	--	25 to 50	150	Single or double	✓	✓	✓	✓	35	1 to 2	28	22	--	
700	550	--	25 to 100	200		✓	✓	✓	✓	45	1 to 4	28	22	--	
850	550	--	25 to 100	250		✓	✓	✓	✓	55	1 to 4	34	22	--	
1000	550	--	25 to 100	300		✓	✓	✓	✓	65	1 to 4	40	22	--	
1250	700	--	25 to 100	350		✓	✓	---	✓	80	1 to 4	50	28	--	
1400	700	--	25 to 100	400		✓	✓	---	✓	90	1 to 4	56	28	--	
--	700	--	25 to 100	450		✓	✓	---	✓	100	1 to 4	--	28	--	
--	850	--	25 to 100	500	Double 	✓	✓	---	✓	110	1 to 4	--	34	--	
--	850	--	25 to 100	550		✓	✓	---	---	125	1 to 4	--	34	--	
--	1000	--	25 to 100	600		✓	✓	---	---	135	1 to 4	--	40	--	
--	1000	--	25 to 100	650		✓	✓	---	---	145	1 to 4	--	40	--	
--	1150	--	25 to 100	700		✓	✓	---	---	155	1 to 4	--	46	--	
--	1150	--	25 to 100	750		✓	✓	---	---	170	1 to 4	--	46	--	
--	1300	--	25 to 100	800		✓	✓	---	---	180	1 to 4	--	52	--	
--	1300	1200	25 to 100	850		Double or triple	✓	✓	---	---	190	1 to 4	--	52	48
--	1400	1200	25 to 100	900			✓	✓	---	---	200	1 to 4	--	56	48
--	1400	1200	25 to 100	950			✓	✓	---	---	215	1 to 4	--	56	48
--	1400	1200	25 to 100	1000	✓		✓	---	---	225	1 to 4	--	56	48	
--	--	1250	25 to 100	1050	Triple 	✓	✓	---	---	235	1 to 4	--	--	50	
--	--	1250	25 to 100	1100		✓	✓	---	---	245	1 to 4	--	--	50	
--	--	1250	25 to 100	1150		✓	✓	---	---	260	1 to 4	--	--	50	
--	--	1300	25 to 100	1200		✓	✓	---	---	270	1 to 4	--	--	52	
--	--	1300	25 to 100	1250		✓	✓	---	---	280	1 to 4	--	--	52	
--	--	1400	25 to 100	1300		✓	✓	---	---	290	1 to 4	--	--	56	
--	--	1450	25 to 100	1350		✓	✓	---	---	305	1 to 4	--	--	58	
--	--	1500	25 to 100	1400		✓	✓	---	---	315	1 to 4	--	--	60	
--	--	1550	25 to 100	1450		✓	✓	---	---	325	1 to 4	--	--	62	
Multiple devices installed in parallel			25 to 100	1500		Multiple devices installed in parallel 	✓	✓	---	---	335	1 to 4			
			25 to 100	1550	✓		✓	---	---	350	1 to 4				
			25 to 100	1600	✓		✓	---	---	360	1 to 4				
			25 to 100	1650	✓		✓	---	---	370	1 to 4				
			25 to 100	1700	✓		✓	---	---	380	1 to 4				
			25 to 100	1750	✓		✓	---	---	395	1 to 4				
			25 to 100	1800	✓		✓	---	---	405	1 to 4				
			25 to 100	1850	✓		✓	---	---	415	1 to 4				
			25 to 100	1900	✓		✓	---	---	425	1 to 4				
			25 to 100	1950	✓		✓	---	---	440	1 to 4				
			25 to 100	2000	✓		✓	---	---	450	1 to 4				
			25 to 100	2100	---		✓	---	---	470	1 to 4				
			25 to 100	2200	---		✓	---	---	495	1 to 4				
			25 to 100	2300	---		✓	---	---	515	1 to 4				
			25 to 100	2400	---		✓	---	---	540	1 to 4				
			25 to 100	2500	---		✓	---	---	560	1 to 4				
			25 to 100	2600	---		✓	---	---	585	1 to 4				
			25 to 100	2700	---		✓	---	---	605	1 to 4				
			25 to 100	2800	---		✓	---	---	630	1 to 4				
			25 to 100	2900	---		✓	---	---	650	1 to 4				
		25 to 100	3000	---	✓	---	---	675	1 to 4						
		25 to 100	3500	---	✓	---	---	785	1 to 4						
		25 to 100	4000	---	✓	---	---	900	1 to 4						
		25 to 100	4500	---	✓	---	---	1010	1 to 4						
		25 to 100	5000	---	✓	---	---	1125	1 to 4						

TABLE NOTES

- Devices are designed to provide deflection with self-centring even beyond Δ_{ult} (as a secondary fuse) with $\Delta_{max} = 1.5 \Delta_{ult}$ and an overstrength factor of 1.35
- Given the slight non linearity at the joint slip stage, the F_{slip} is determined as the intersect of the straight lines matching the initial and second stiffness of the flag-shaped curve.
- Δ_{slip} (comparable to SLS) is kept to be about 1mm, 1.5mm and 2mm for 2-bolt, 4-bolt and 6-bolt devices, respectively (excluding the deflection resulting from the attachments such as pins, brackets and anchor bolts).

STRUCTURAL MODELING GUIDE

Engineers have the freedom to choose what design approach is most suitable for determining the seismic requirements of their projects.

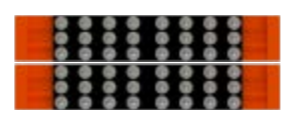
This guide covers the Force-Based Design (FBD), and Displacement-Based Design (DBD) approaches with simple reference examples. Please reach out if you would like to discuss the Non-Linear Time History Analysis (NLTHA) approach. Whether FBD or DBD design method is used, a cyclic non-linear push-over structural analysis must be performed.

To ensure the optimum solution is provided for your project, please relay your modelling finds to our engineering team for your project.

Force-Based Design (FBD) page 58-60

This is the most common approach but also the most conservative one. In this approach, an equivalent ductility is assumed at the start.

By using Tectonus devices, structures can easily reach equivalent ductility values of 3 and higher. Seismic forces are determined using the NZS1170.5 procedure, followed by a numerical model analysis to determine the structural seismic demands. The results of this first linear analysis are then used to determine the characteristics of the devices within the Lateral Load Resisting System.

In the next step, a numerical model incorporating the Tectonus devices will be constructed, and a static nonlinear push-over analyses will be performed. The results of these analyses are used to verify the member forces and structure drifts against the design criteria. More details and an example using the FBD approach are provided in this catalogue.

Custom Projects Beyond the Usual

Tectonus offers a standard range of devices, however the devices can be customized and used in parallel or in custom arrangements and specifications tailored to individual project.

Tectonus devices can be customised to well above 500 kN (110 kips) and have been used in parallel to resist loads up to 5000 kN (1100 kips).

Displacement Based Design (DBD) page 62-64

This method is based on the principle that displacements are controlled and the member force demands are determined to meet those displacement limits. An equivalent single-degree of freedom model is determined with an equivalent stiffness, representing the actual structure.

From this simple model, a general structural response is determined based on the SLS or wind loads and ULS seismic demands. From this structural response, the characteristics of the devices in the structure are determined and a non-linear push-over analysis is conducted to ensure that the structural model is in accordance with the DBD model response. More details and an example using the DBD approach are provided in this catalogue.

Technical Support

Modelling support is provided by the Tectonus engineering team for either method used for designing with the devices. The team offers workshops, technical sessions and training to help facilitate project and modelling development. More information and resources can be found on the tectonus.com website.

STRUCTURAL MODELING SOFTWARE

Our devices can be easily integrated in the ETABS and SAP2000 structural analysis and design software.

It allows the designer to accurately calibrate the parameters according to the requirements of the project.

In ETABS/SAP2000, the device can be modelled using the "Damper – Friction Spring" link element. This function accurately represents the flag-shaped hysteresis of a device provided its parameters are properly calibrated in accordance with the design parameters of the joint. The parameters can be defined for any of the six translational and rotational degrees of freedom.

The design parameters of the our devices are:

- F_{slip}** Slip force
- F_{ult}** Ultimate force in the device at the end of loading
- F_{restoring}** Restoring force
- F_{residual}** Residual force in the device at end of unloading
- Δ_{slip}** Initial elastic deflection of the device before slip
- Δ_{ult}** Ultimate displacement
- K_{initial}** Initial stiffness of the device before slip
- K_{loading}** Loading stiffness
- K_{unloading}** Unloading stiffness

Damper – Friction Spring design parameters:

- Initial (Nonslipping) Stiffness = $K_{initial}$
- Slipping Stiffness (Loading) = $K_{loading}$
- Slipping Stiffness (Unloading) = $K_{unloading}$
- Pre-compression displacement = $\Delta_{slip} - (F_{slip} / k_{loading})$
- Stop displacement = Δ_{ult}
- Active direction (Tension/Compression/Both): should be specified based on the application requirement.

By defining these parameters, the rest of the device parameters (Δ_{slip} , F_{ult} , $F_{restoring}$ and $F_{residual}$) will be automatically adjusted.

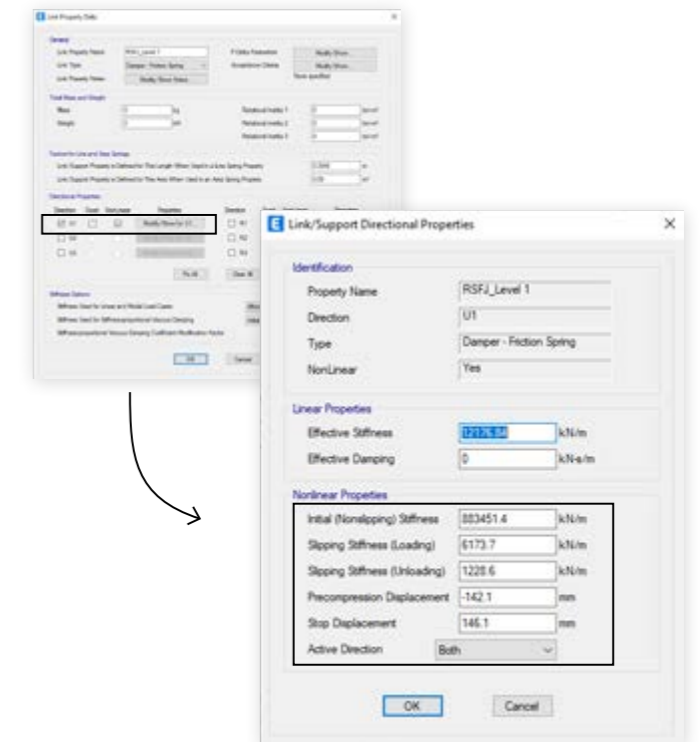
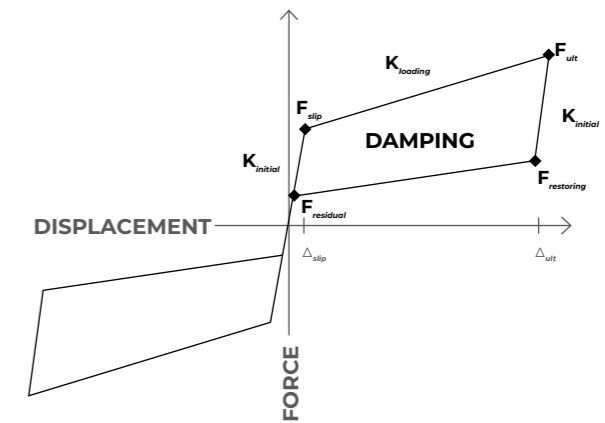
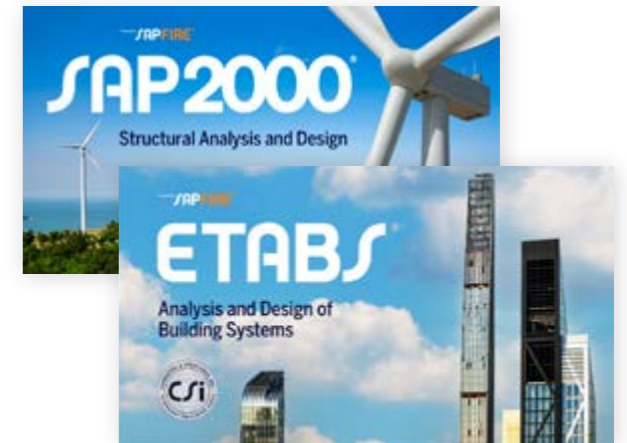

Note: Screenshot of ETABS/SAP2000 windows with imperial units is not shown.

The Force-Based Design (FBD) is the most common approach but also the most conservative one. In this approach, an equivalent ductility is assumed at the start.

See Flow Chart below and step by step example on following pages references.

FORCE-BASED DESIGN (FBD) — EXAMPLE REFERENCE

Structure Three-story steel frame with Tectonus devices in braces
 Building Type Office or similar
 Seismic Weights 335 kN (75.3 kips) is assumed for all stories
 Location Wellington, New Zealand with soil type D (deep soil).

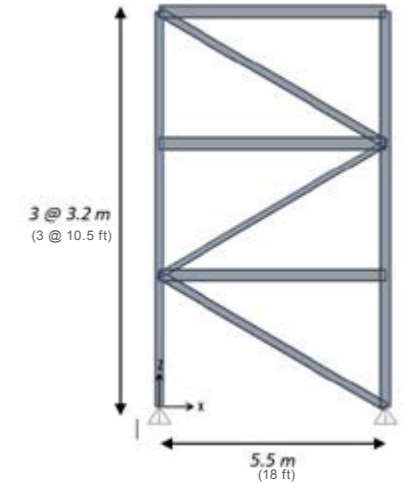

The target Ultimate Limit State (ULS) lateral drift is 2.5% and the target Serviceability Limit State (SLS) drift limit 0.33%. The columns are continuous and beams and diagonal braces are pinned. Note that in real cases the target drift is in the range of 1.0% to 1.5% to protect the secondary and non — structural elements.

The right procedure in the provided step-by-step design flowchart is used where the assumed structural ductility factor (μ) is verified by non-linear dynamic time-history simulations:

Assume an equivalent ductility factor of $\mu = 3$.

1. Determine the Ultimate Limit State (ULS) seismic forces applied to the lateral load resisting system ($F_{ult,sys}$) using the Equivalent Static Method (ESM). For the initial estimate, use clause C4.1.2.2 (NZS 1170.5) to calculate the period of the structure (T_1). Following this step, the base-shear of the structure is determined as 427 kN (96 kips). Accordingly, the seismic story shears were

determined as 230 kN (51.71 kips), 131 kN (29.45 kips) and 65 kN (14.61 kips) for the roof, second story and the first story, respectively. The period of the structure (T_1) is determined as 0.34 seconds using NZS 1170.5 C4.1.2.2.

2. Model the structure in ETABS/SAP2000. The lateral load resisting members can be modelled using linear elastic members (there is no need to model the flag-shaped hysteresis of the devices at this stage).

The structure is modelled in SAP2000 and the braces were modelled as linear elastic members with standard UC sections.

3. Distribute The ULS Seismic loads In the table distribute the ULS seismic loads (obtained from ESM) in the structure to find out the forces in the members (and the corresponding devices attached to those members (F_{ult})):

→ CHECK: Is the period of the structure (T_1) from the modal analysis different than what is assumed in Step 1?
 The period of the structure (T_1) from the model analysis is 0.33 seconds which is consistent with what is assumed in Step 1.

The ULS seismic loads were applied to the structure. The force demand in the braces and the required UC sections were:

$F_{ult,1} = 503 \text{ kN}$ (113.08 kips) (200 UC 52.2)	$F_{ult,2} = 402 \text{ kN}$ (90.37 kips) (200 UC 46.2)	$F_{ult,3} = 268 \text{ kN}$ (60.25 kips) (200 UC 46.2)
---	--	--

The elastic lateral deformation of the structure is determined as 1.5% based on the numerical model.

START

Assume an equivalent ductility factor of $\mu = 2 \sim 3$ for start

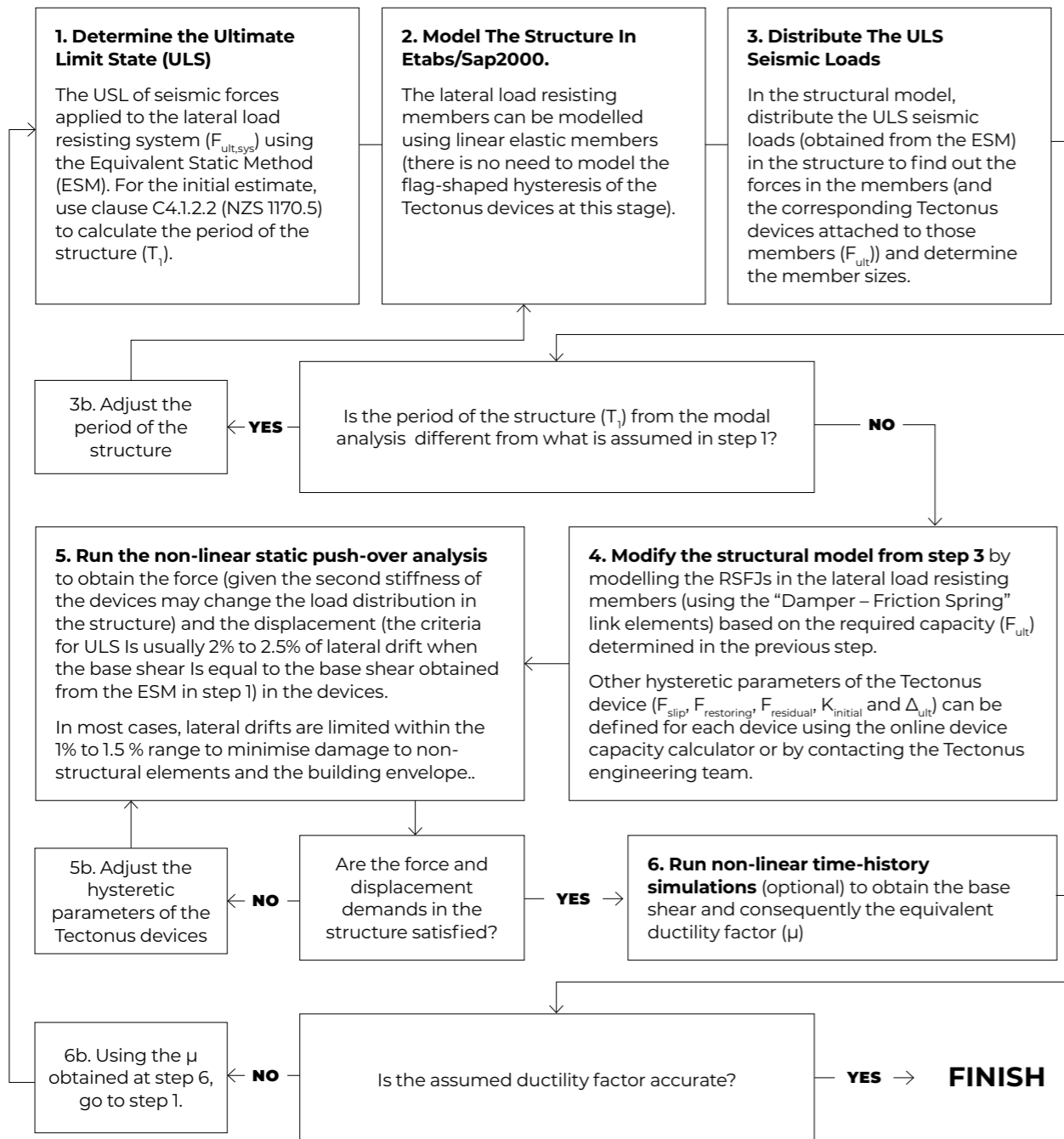

4. Modify the structural model from step 3

by modelling the devices in the lateral load resisting members (using the “Damper – Friction Spring” link elements) based on the required capacity (F_{ult}) determined in the previous step. Other hysteretic parameters of the device (F_{slip} , $F_{restoring}$, $F_{residual}$, $K_{initial}$ and Δ_{ult}) can be defined for each device according to the

Tectonus product tables. Based on the target ULS drift (2.5%) and the specified elastic drift determined in the previous step (1.5%), the displacement demand of the braces was estimated as 85 mm. Based on the force demands specified in the previous step, the following devices were adopted for the braces:

Roof: 1 device w/ F_{ult} = 250 kN (80mm) (1 device w/ F_{ult} = 55 kips (3.15in))	2nd level: 1 device w/ F_{ult} = 400 kN (80mm) (1 device w/ F_{ult} = 90 kips (3.15in))	1st Level: 2 devices w/ F_{ult} = 250 kN (80mm) (2 devices w/ F_{ult} = 55kips (3.15in))
--	---	--

The target Ultimate Limit State (ULS) lateral drift is 2.5% and the target Serviceability Limit State (SLS) drift limit 0.33%. The columns are continuous and beams and diagonal braces are pinned. Note that in real cases the target drift is in the range of 1.0% to 1.5% to protect the secondary and non — structural elements.

The recommended procedure in the provided step-by-step design flowchart is used where the assumed structural ductility factor (μ) is verified by non-linear dynamic time-history simulations:

The braces were modelled using “Damper-Friction Spring” link elements and the parameters were determined based on the described method in this hand-out. The table below summarises the numerical characteristics of the braces. Please note that for this design example, the initial stiffness of the devices ($K_{initial}$) is considered equal to the elastic stiffness of the adopted UC section. For different cases, this should be determined based on the target SLS drift and the elastic stiffness of the device, brace body, pins, brackets and other attachments.

ETABS / SAP 2000 Parameters

Level	Adopted device	Initial (Non-slipping) Stiffness	Slipping Stiffness (Loading)	Slipping Stiffness (Unloading)	Precompression displacement	Stop Displacement (mm)
Roof	1 device w/ F_{ult} = 250 kN (80mm) (1 device w/ F_{ult} = 55 kips (3.15 in))	209 kN/mm (47 kips/in)	2.94 kN/mm (0.66 kips/in)	1.34 kN/mm (0.30 kips/in)	-70mm (-2.76in)	70mm (2.76 in)
2 nd level	1 device w/ F_{ult} = 400 kN (80mm) (1 device w/ F_{ult} = 90 kips (3.15in))	185 kN/mm (41.6 kips/in)	2.35 kN/mm (0.53 kips/in)	0.93 kN/mm (0.21 kips/in)	-70mm (-2.76in)	70mm (2.76 in)
1 st level	2 devices w/ F_{ult} = 250 kN (80 mm) (2 devices w/ F_{ult} = 55kips (3.15 in))	185 kN/mm (41.6 kips/in)	1.47 kN/mm (0.33 kips/in)	0.67 kN/mm (0.15 kips/in)	-70mm (-2.76in)	70mm (2.76 in)



5. Run the non-linear static push-over analysis

to obtain the force (given the second stiffness of the devices may change the load distribution in the structure) and the displacement (the criteria for ULS is usually 2% to 2.5% of lateral drift when the base shear is equal to the base shear obtained from the ESM in step 1) in the RSFJs. The result of the non-linear static push-over analysis is shown below. The structure is pushed

to 2.5% of lateral drift corresponding to 240 mm of deflection at the roof. It can be seen that the maximum force in the system is 386 kN (86.78kips) which is less than the demand specified by the ESM method (427 kN or 96kips). This most likely means that the devices are not fully expanded and did not reach their maximum capacity at the given ULS drift.

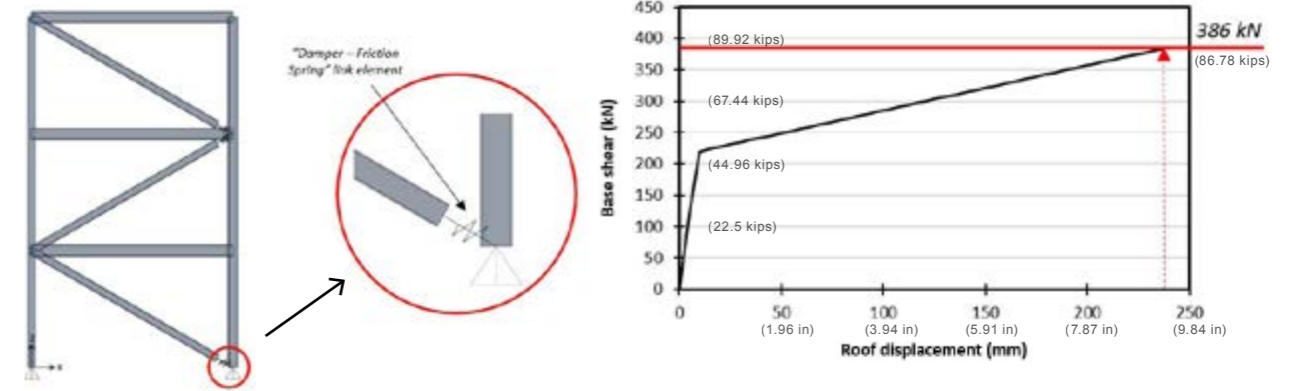

→ CHECK: Are the force and displacement demands in the structure satisfied? The displacement capacity of the devices need to be adjusted at this stage to achieve the force demand (427kN) (96kips).

Adjust the hysteretic parameters of the devices. After two iterations with Δ_{ult} at 80mm (3.15in) and 70mm (2.76in), the force demand is reached at the given drift. The maximum displacement of the devices (Δ_{ult}) is changed to 70mm (2.76in). The adjusted specifications of the devices are:

ETABS / SAP 2000 Parameters

Level	Adopted device	Initial (Non-slipping) Stiffness	Slipping Stiffness (Loading)	Slipping Stiffness (Unloading)	Precompression displacement	Stop Displacement (mm)
Roof	1 device w/ F_{ult} = 250 kN (80mm) (1 device w/ F_{ult} = 55 kips (3.15 in))	209 kN/mm (47 kips/in)	3.57 kN/mm (0.80 kips/in)	1.63 kN/mm (0.37 kips/in)	-70 mm (-2.76 in)	70 mm (2.76 in)
2 nd level	1 device w/ F_{ult} = 400 kN (80mm) (1 device w/ F_{ult} = 90 kips (3.15in))	185 kN/mm (41.6 kips/in)	2.86 kN/mm (0.64 kips/in)	1.13 kN/mm (0.25 kips/in)	-70 mm (-2.76 in)	70 mm (2.76 in)
1 st level	2 devices w/ F_{ult} = 250 kN (80mm) (2 devices w/ F_{ult} = 55kips (3.15 in))	185 kN/mm (41.6 kips/in)	1.78 kN/mm (0.40 kips/in)	0.81kN/mm (0.41 kips/in)	-70 mm (-2.76 in)	70 mm (2.76 in)

Repeating Step 4 and Step 5, the result of the non-linear static pushover analysis with the adjusted RSFJs is:

It can be seen that the new base-shear is 424 kN (95.32 kips) which matches the ESM base-shear demand. The roof drift at the slip threshold is approximately 0.15% which satisfies the SLS drift limit

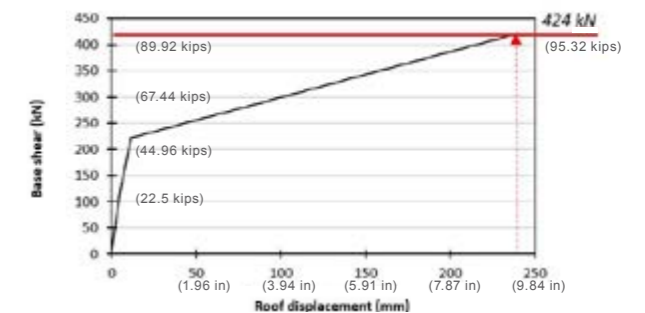

6. Run non-linear time-history simulations

to obtain the base shear and consequently the equivalent ductility factor μ . Non-linear dynamic time-history simulations are carried out to investigate the behaviour of the structure.

The seismic events were considered for a 500 years return period and soil type D (deep soil) located in Wellington, New Zealand. See below for the considered events for these simulations.

→ CHECK: Is the assumed ductility factor accurate?

El Centro, Imperial Valley, USA	May-40	Loma Prieta, USA	Oct-89
Northridge, USA	Jan-94	San Fernando, USA	Feb-71
Landers, USA	Jun-92	Duzce, Turkey	Nov-99
Christchurch, New Zealand	Feb-11	Hokkaido, Japan	Sep-03
Kobe, Japan	Jan-95	Yarimka, Turkey	Aug-99
Chi Chi, Taiwan	Sep-99	Caleta de Campos, Mexico	Sep-85
Chihuahua, Mexico	Nov-28		

From the results of the time-history simulations (the average base-shear), the equivalent ductility factor is $\mu = 3.47$. Given that this ductility factor is relatively higher than the first assumption in Step 1 ($\mu = 3$), the procedure needs to be repeated from the start with the new ductility factor of $\mu = 3.47$. Also, the average displacement demand of the structure is 2.19% which is less than the ULS limit (2.5%). Following the procedure with the new ductility factor, the base-shear from the ESM is reduced to 385 kN (86.55 kips)

(Step 1).
Following Steps 2 and 3, the force demand and the adopted UC sections for the braces are:

- $F_{ult,1} = 450 \text{ kN}$ (200 UC 52.2) (101.16 kips)

- $F_{ult,2} = 374 \text{ kN}$ (200 UC 46.2) (84.08 kips)

- $F_{ult,3} = 245 \text{ kN}$ (200 UC 46.2) (55.08 kips)

ETABS / SAP 2000 Parameters						
Level	Adopted device	Initial (Non-slipping) Stiffness	Slipping Stiffness (Loading)	Slipping Stiffness (Unloading)	Precompression displacement	Stop Displacement (mm)
Roof	1 device w/ $F_{ult} = 250 \text{ kN}$ (80mm) (1 device w/ $F_{ult} = 55 \text{ kips}$ (3.15 in))	209 kN/mm (47 kips/in)	3.12 kN/mm (0.70 kips/in)	1.42 kN/mm (0.32 kips/in)	-70 mm (-2.76 in)	70 mm (2.76 in)
2 nd level	1 device w/ $F_{ult} = 400 \text{ kN}$ (80 mm) (1 device w/ $F_{ult} = 90 \text{ kips}$ (3.15 in))	185 kN/mm (41.6 kips/in)	2.50 kN/mm (0.56 kips/in)	0.99 kN/mm (0.22 kips/in)	-70 mm (-2.76 in)	70 mm (2.76 in)
1 st level	2 devices w/ $F_{ult} = 250 \text{ kN}$ (80 mm) (2 devices w/ $F_{ult} = 55 \text{ kips}$ (3.15 in))	185 kN/mm (41.6 kips/in)	1.56 kN/mm (0.35 kips/in)	0.71 kN/mm (0.16 kips/in)	-70 mm (-2.76 in)	70 mm (2.76 in)

Following Step 5, the result of the new non-linear static push-over analysis is shown below.

As can be seen, the achieved base-shear (392 kN) (88.13 kips) matches well with the ESM base-shear demand (385 kN) (86.55 kips).

From the results of the time-history simulations with the new device configurations, the new average ductility factor is $\mu = 3.41$ which is very close (2% difference) to the assumed ductility factor at Step 1.

This means that an equivalent ductility factor of $\mu = 3.4$ can confidently be adopted for the given structure.

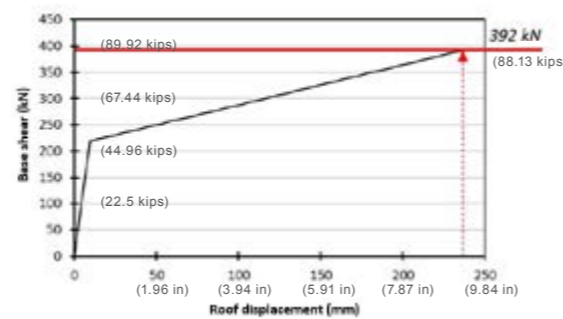

DISPLACEMENT-BASED DESIGN (DBD) — DESIGN IMPLICATIONS

This method is based on the principle that displacements are controlled and the member force demands are determined to meet those displacement limits.

See Design Implications and Example references

Damping Ratio

Generally, a displacement-based approach is recommended to design the systems with Tectonus devices. The main reason being that in this method, the damping ratio of the system is directly incorporated into the calculation to scale the demand spectra.

Based on the product chosen and from the results of the cyclic pushover analysis on the structure, the damping ratio of the system can be determined using the equation below following the area-based approach.

$$\xi_{hyst} = \frac{2 A_1}{\pi A_2}$$

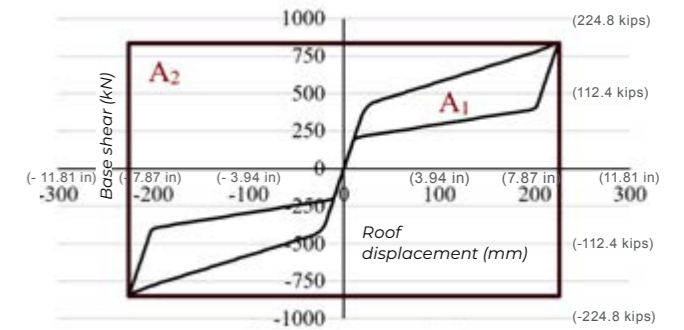

Acceleration-Displacement Response Spectra (ADRS) Curves

At the concept and detailed design stages, an efficient way to design the systems with Tectonus devices is the use of the Acceleration-Displacement Response Spectra (ADRS) curve to specify the F_{slip} and F_{ult} of the system based on the scaled and unscaled demand curves.

In this approach, the SLS1 or SLS2 (depending on the importance level of the structure) would determine the F_{slip} of the system or in other words, the threshold in which the first device in the system starts to open. On the other hand, the ULS demand curve which is scaled based on the

damping ratio determines the F_{ult} of the system before the secondary fuse starts to activate.

Firstly, the designer decides about the drift limit of the structure before the devices start to open. This is usually in the range of 0.33% depending on the details used for the non-structural elements. The intersection between this drift limit and the SLS spectra (or wind in rare cases) determines the base shear in which the devices start to open. All the remaining parts of the device remain elastic up to $1.5 \cdot F_{ult}$.

Secondly, the designer decides on the lateral drift that the structure is limited to at the design level earthquake. This is usually in the range of 1.5% to protect the secondary and non-structural components.

The intersection between this drift limit and the scaled ULS spectra (based on the amount of damping provided) determines the base shear in which the devices are at full expansion. The figure shows the design philosophy described.

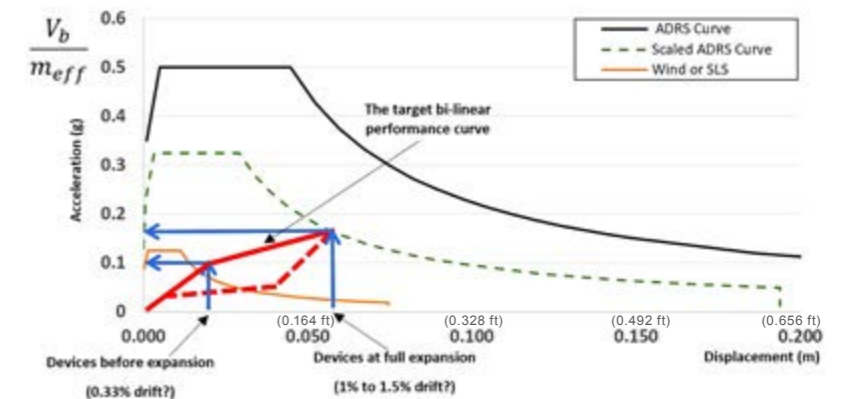

The Collapse-Prevention Secondary Fuse

The Tectonus device is designed in a way that all components remain elastic up to the design load (F_{ult} of the device). However, with the aim of collapse prevention in cases that the applied loads are higher than the design earthquake loads, a collapse-prevention secondary fuse in the body of the device is considered. When the load on the device increases beyond its maximum capacity (F_{ult}), the clamping bolts (or rods) start to yield. The inelastic elongation of the bolts provides additional travel distance for the joint allowing it to maintain a ductile behaviour (without the device locking at any stage) up to 1.5 times of the design displacement.

The devices are designed in a way that the maximum load in the joint after the full activation of the secondary fuse is 1.25 times higher than the design F_{ult} . In other words, the over-strength factor applicable for the device is 1.25 and the other parts of the structure should be designed with a minimum over-strength factor of 1.25 to maintain

the hierarchy of strengths following the capacity design principles. Accordingly, an over-strength factor of 1.5 is usually considered for the attachments and the main structural members to take the material variability and dynamic effects into account.

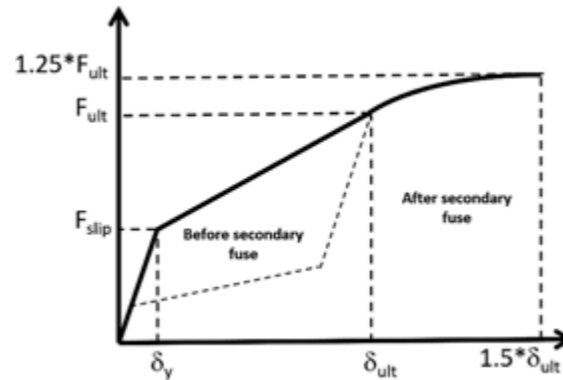

Simple Lateral Mechanism Analysis (SLaMA)

The New Zealand seismic assessment of existing structures guidelines recommend in all cases that a simplified nonlinear pushover analysis be conducted using a Simple Lateral Mechanism Analysis (SLaMA).

The SLaMA approach offers a simplified means of assessing the probable inelastic deformation mechanisms and lateral strength of a structure by running a pushover analysis on the identified lateral mechanisms. In many cases, the capacity curve cannot satisfy the demand curve and this would decrease the seismic score of the system (%NBS).

In order to solve this problem and increase the seismic score of the structure, either the displacement capacity of the system needs to be increased or the demand spectrum should be further scaled down. Increasing the displacement capacity is not always possible given the limited deformation capacity of the gravity resisting members.

For seismic retrofitting cases, Tectonus devices can be added to the existing lateral load resisting system. The demand spectra can then be further scaled based on the damping provided by the devices so the capacity curve can intersect with the demand.

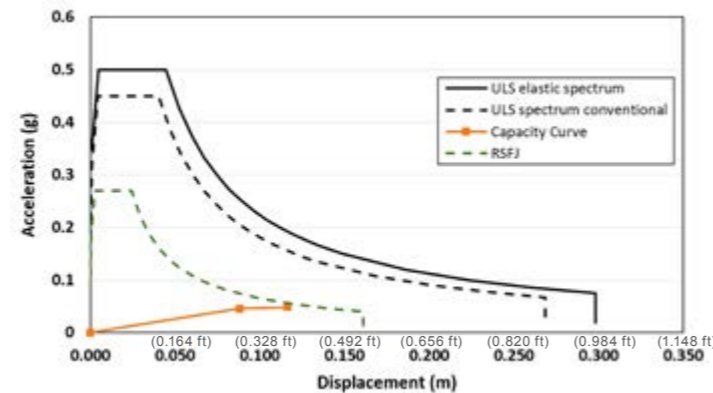

DISPLACEMENT-BASED DESIGN (DBD) — EXAMPLE REFERENCE

- Structure: Three-story rocking reinforced concrete wall with Tectonus hold-downs
- Building Type: Office with an importance level of 2. The return period considered for the design level earthquake is 1/500 years.
- Seismic Weights: 360 kN (80.93 kips) and 180 kN (40.47 kips) were assumed for floors 1 to 2 and the roof, respectively.
- Location: Wellington New Zealand with a hazard factor of Z=0.4 and soil type D (deep or soft soil).

In order to protect the non- and secondary structural elements from damage, it was decided that the inter-story drifts are kept under 0.3% for the Serviceability Limit State (SLS) and 1.5% for the Ultimate Limit State (ULS). The figure to the right shows the general arrangement of the rocking wall.

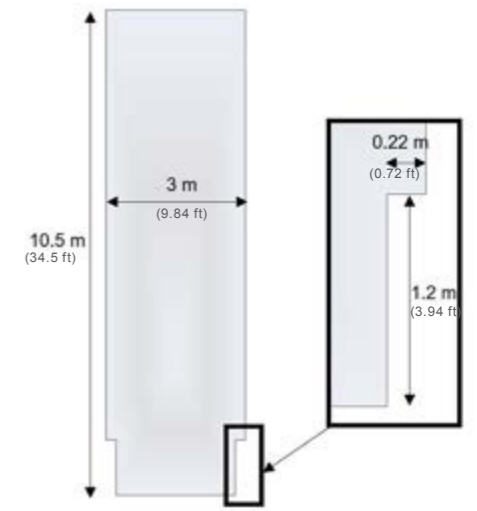

Note: The layout of the devices can be discussed with Tectonus at the early stages of design. The structure is considered as regular and symmetric thus mostly dominated by the first mode of vibration.

The following steps were taken to design the Tectonus hold-downs using a displacement-based approach and ADRS curves.

1. Determine the characteristics of the equivalent Single Degree of Freedom (SDOF) structure

As per the principles of displacement-based design, the structure is represented by an equivalent SDOF system with the following characteristics.

- Characteristics of the equivalent SDOF structure
- Height in meters (feet)
- Mass in tonnes (tons)

SDOF peak design displacement

$$\Delta_d = \frac{\sum_{i=1}^n m_i \Delta_i^2}{\sum_{i=1}^n m_i \Delta_i} = 0.11 \text{ m} \quad (0.36 \text{ ft})$$

SDOF effective mass

$$m_e = \frac{\sum_{i=1}^n m_i \Delta_i}{\Delta_d} = 78.2 \text{ tonnes} \quad (86.20 \text{ tons})$$

SDOF effective height

$$H_e = \frac{\sum_{i=1}^n m_i \Delta_i h_i}{\sum_{i=1}^n m_i \Delta_i} = 7.4 \text{ m} \quad (24.28 \text{ ft})$$

Level	Height (h_i)	Mass (m_i)	Δ_i	$m_i \Delta_i$	$m_i \Delta_i^2$	$m_i \Delta_i h_i$
Roof	10.5 m (34.5 ft)	18.3 tonnes (20.17 tons)	0.16 m (0.525 ft)	2.89 (10.59)	0.46 (5.56)	30.34 (364.78)
2 nd level	7 m (22.97 ft)	36.7 tonnes (40.45 tons)	0.11 m (0.36 ft)	3.85 (14.60)	0.4 (5.27)	29.97 (335.30)
1 st level	3.5 m (11.48 ft)	36.7 tonnes (40.45 tons)	0.05 m (0.16 ft)	1.93 (6.64)	0.1 (1.09)	6.74 (76.20)
Sum				8.67 (31.83)	0.96 (11.92)	64.06 (776.28)

2. Determine the hysteretic and elastic damping ratio of the system and calculate the scale factor

For this example, an elastic damping ratio of 3% and a hysteretic damping ratio of 14% (provided by the devices) are assumed. Note that Tectonus devices can provide a hysteretic damping ratio between 10% to 20% depending on the design. The assumed value for the hysteretic damping ratio in this step is verified at the last step of the procedure.

The scale factor

$$\eta = \sqrt{\frac{7}{2+\xi_{el}+\xi_{hyst}}} = \sqrt{\frac{7}{2+3+14}} = 0.61$$

The spectral scale factor used to scale the demand spectra is calculated using the formula (from Eurocode 8, 1998) as seen above.

3. Plot the Acceleration-Displacement Response-Spectra (ADRS) curves and scale the demand curve based on the calculated scale factor

The acceleration and displacement spectrums for the given location, soil type and return period factor can be derived from the New Zealand Standard NZS 1170.5 (or any equivalent international standard). Note that the limit state at which the structure remains linear elastic is decided to be the SLS earthquake.

For the international standards that do not have serviceability earthquake requirements, the wind design spectra can be used instead.

$$S_d = \frac{T^2}{4\pi^2} S_a$$

The red curve shows the SLS spectrums and the black curve shows the ULS design spectrums. The displacement spectrum is plotted from the acceleration spectrum using this equation:

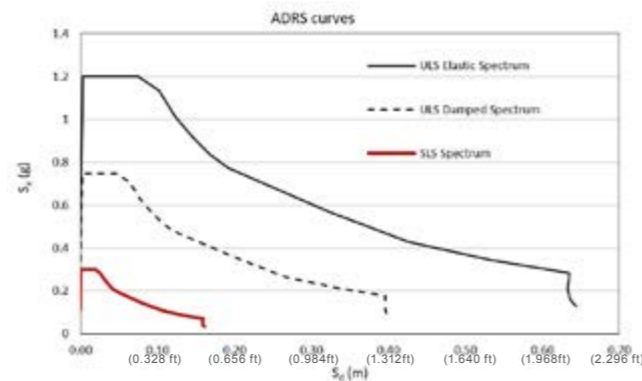
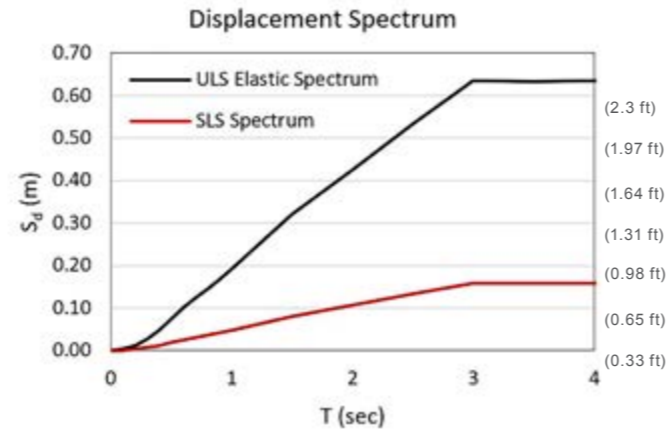
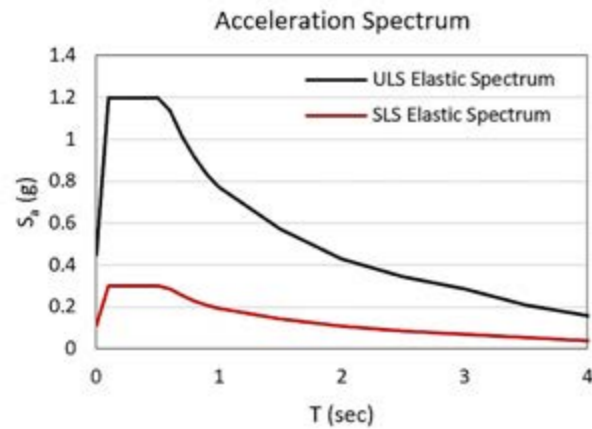

The ADRS curves can be plotted using the acceleration and displacement spectrums in which the horizontal axis is the displacement spectrum (\$S_d\$) and the vertical axis is the acceleration spectrum (\$S_a\$). The black dashed curve shows the design spectra scaled using the scale factor specified in Step 2.

4. Determine the \$F_{slip,sys}\$ and \$F_{ult,sys}\$ based on the considered drift limit states

The horizontal axis of the ADRS curves shows the displacements. As mentioned earlier, the drift limit corresponding to the SLS is 0.3%. The intersection of this value on the horizontal axis (corresponding to 0.022 m deflection in the equivalent SDOF system) and the SLS curve (the red curve in the figure below) will give the \$F_{slip,sys}\$ or the force in which the first device in the system start to deform. Note that the vertical axis of the ADRS curve represents (\$V_b/m_{eff}\$). The red curve could be SLS1, SLS2 or the design wind spectrum for cases where the service earthquake consideration is not a requirement.

The drift limit for the design level earthquake was considered as 1.5%. Similarly, the intersection between this value on the horizontal axis (correspond to 0.11 m (4.33in) deflection in the equivalent SDOF system) and the scaled ULS curve (the black dashed curve) will give \$F_{ult,sys}\$ or the base shear in which the devices are at full expansion.

For this case, \$F_{slip,sys} = 230\$ kN (51.71 kips) (0.3*9.81*78.2) and \$F_{ult,sys} = 400\$ kN (89.92 kips) (0.51*9.81*78.2 = 391 kN (87.9 kips) rounded up to 400 kN (89.92 kips)) were specified. The green lines below shows the target backbone performance of the structure.

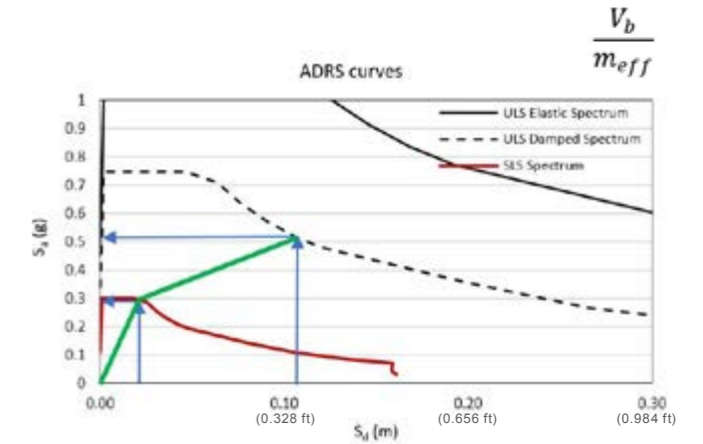

5. Calculate the force and displacement (\$F_{slip}\$, \$F_{ult}\$ and \$\Delta_{ult}\$) demands of the Tectonus devices

In this step, the base shears found from the last step are distributed in the structure and the force and displacement demands in the devices are calculated. For this example, taking the moments around the rocking toe of the structure, the following characteristics are found for the Tectonus hold-downs. Note that for more complicated structures, a numerical model may need

to be developed to distribute the lateral seismic loads and calculated force and displacement demands in the structure.

\$F_{slip} = 630\$ kN (141.63 kips)
 \$F_{ult} = 1065\$ kN (239.42 kips)
 \$\Delta_{ult} = 40\$ mm (1.57 in)

From the Tectonus product catalogue, 3 devices w/ \$F_{ult} = 350\$ kN (80 kips) is selected for this application.

6. Determine the full flag-shape response of the devices in the system

In this step, the full flag-shape response of all devices that are used should be calculated. At this stage, based on the device capacity selected from the Tectonus product catalogue (or in the case that a customized product is required), the designer may need to contact the Tectonus Engineering team and discuss the products required. Tectonus will send the flag-shape response of the devices.

The flag-shape response of the selected device for this example is shown to the right.

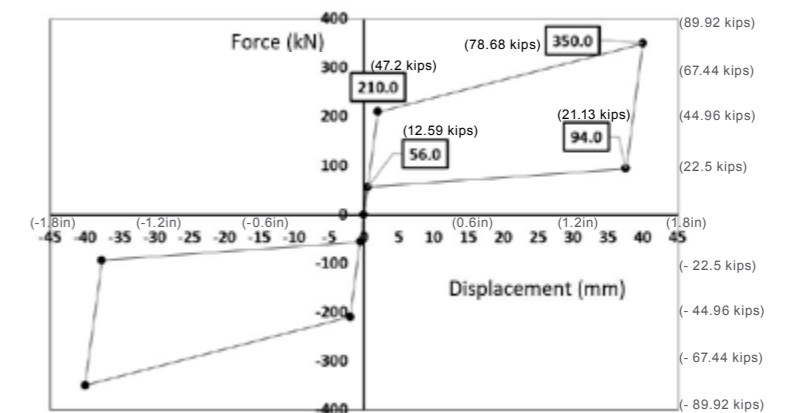

7. Develop a numerical model for the structure including the Tectonus devices

A numerical model in SAP2000 is developed for the shear wall with Tectonus devices modelled as “Damper-Friction Spring” link elements. The table below shows

Parameter	Value
Initial stiffness	320 kN/mm (71.94 kips/in)
Loading Stiffness	10.96 kN/mm (2.46 kips/in)
Unloading stiffness	3.02 kN/mm (0.68 kips/in)
Pre-compression displacement	-57mm (2.24 in)
Stop displacement	40 mm (1.57 in)

the numerical input used for the link element. A gap element is also used at the rocking toe to represent the foundation level.

Note that one link element is used to model the three devices working in parallel. The figure below shows the numerical model developed in SAP2000.

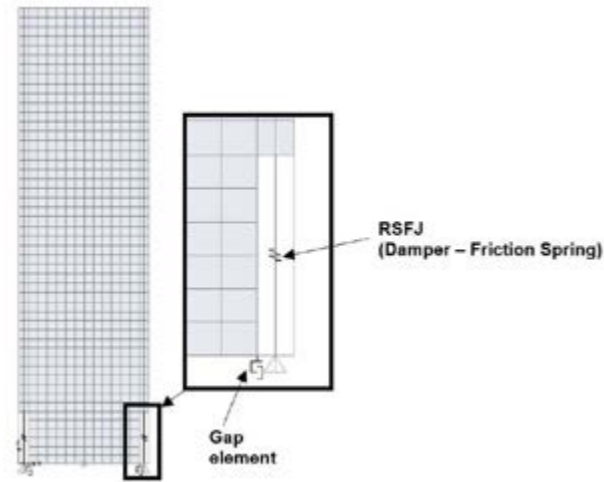

8. Run cyclic pushover analysis on the structure to verify the bi-linear performance of the system and verify the hysteretic damping ratio for the system

The figure to the right shows the results of the non-linear static cyclic pushover analysis carried out on the model.

Following an area-based approach, the hysteretic damping ratio of the structure is calculated using the equation below.

As per equation to the right, this number is consistent with the initial assumption at step 2 of the procedure.

Note that if this value is different from the assumption in step 2, iterations may be required to optimize the design.

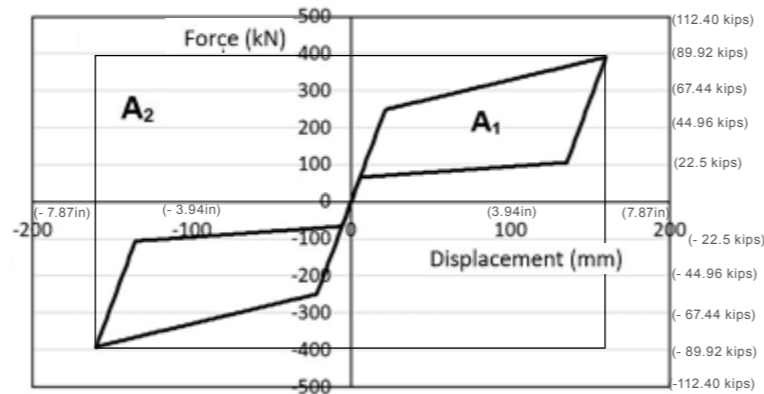

$$\xi_{hyst} = \frac{2A_1}{\pi A_2} = 14.4\%$$





DESIGN GUIDE - DFFJ

TECTONUS DFFJ

Straight swap for a BRB, with 50% savings in structural actions



Tectonus DFFJ is typically used as a brace and is a straight swap for Buckling Restrained Braces (BRBs). Thanks to its massive damping ratio and best-in-class capacity design overstrength factor of 1.15, a Tectonus DFFJ brace can achieve 50% force reduction compared to a BRB. By reducing seismic demand, smart engineers can use this to significantly reduce costs in the superstructure and foundations.

Friction dampers have the advantage of providing very high levels of damping without any yielding components. This means that they can provide stable and repeatable load-deformation behavior without need for replacement.

Depending on the friction surface technology used, the dynamic performance of these dampers can be predictable and stable for the range of frequencies that are typical of earthquake events. However, friction dampers can suffer performance issues due to friction surface degradation and loss of clamping force.

The Tectonus DFFJ overcomes this by application of a proprietary surface layer to the steel plates and use of disc springs which maintains clamping force in the event of any friction surface degradation.

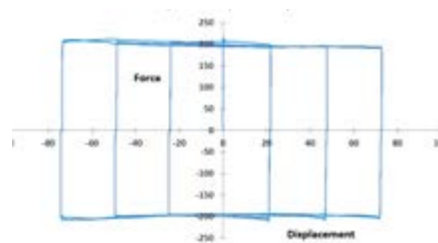

Up to 50% damping
Capacity design overstrength factor 1.15
Elastic-Perfectly-Plastic hysteresis

PROJECT EXAMPLES

Tectonus DFFJ is commonly used in braces as a straight swap for a BRB. It can also be used as a shear wall hold down.

Tauranga Shopping Centre
 Location: Tauranga, New Zealand
 Engineers: BCD Group
 Application: Steel Brace Retrofit
 Installed: 2023



AgResearch
 Location: Lincoln, New Zealand
 Engineers: BECA
 Application: CLT shear walls
 Installed: 2021



STRUCTURAL MODELING GUIDE

Tectonus DFFJ can be integrated in ETABS and SAP2000 structural analysis and design software.

This allows engineers and designers to accurately calibrate the parameters according to the requirements of the project.

In ETABS/SAP2000, two methods can be used to model the Tectonus DFFJ, both of which yield similar results in terms of performance and hysteretic response. These functions accurately represent the hysteresis of a device provided that their parameters are properly calibrated in accordance with the design parameters of the Tectonus DFFJ.

The design parameters of Tectonus DFFJ are:

- F_{slip}** Slip force of the device
- F_{ult}** Ultimate force of the device
- Δ_{slip}** Initial elastic deflection of the device before slip
- Δ_{ult}** Ultimate displacement of the device

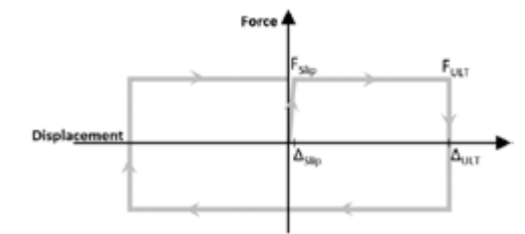
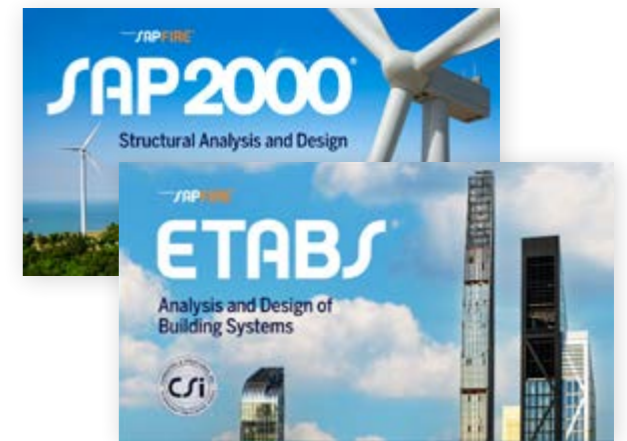

Modelling using the Plastic-Wen link element:

Tectonus DFFJ can be accurately modeled via the non-linear “Plastic (Wen)” link. The respective degree of freedom should be designated (U1 is selected if the device functions axially) and under the non-linear properties the device parameters must be entered as follows:

- Stiffness = F_{slip} / Δ_{slip}
- Yield Strength = F_{slip}
- Post Yield Stiffness Ratio = 0.0
- Yielding Exponent = 20

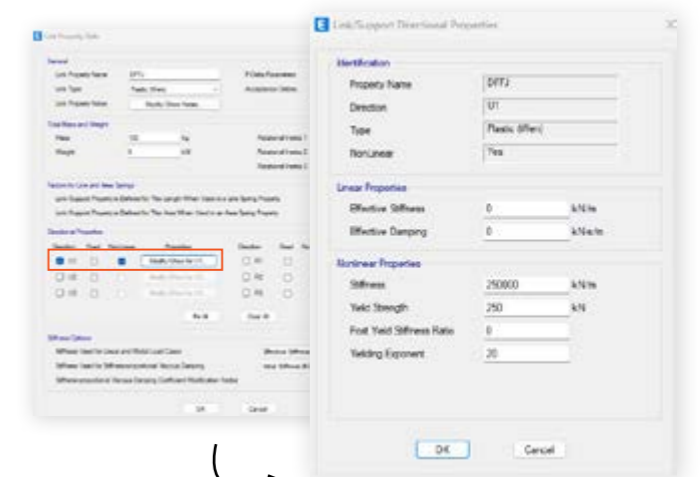

Note: Screenshot of ETABS/SAP2000 windows with imperial units is not shown.

Modelling using the Multi-linear Plastic link element:

Tectonus DFFJ can be accurately modeled via the non-linear “Multi-linear Plastic” link. The respective degree of freedom should be designated (U1 is selected if the device functions axially) and under the non-linear properties “Isotropic” hysteresis type must be selected while entering the required device parameters into the Force-Displacement relation table as follow:

Pt	Displacement (mm)	Force (kN)
1	-Δ _{ULT}	-F _{ULT}
2	-Δ _{slip}	-F _{slip}
3	0	0
4	Δ _{slip}	F _{slip}
5	Δ _{ULT}	F _{ULT}

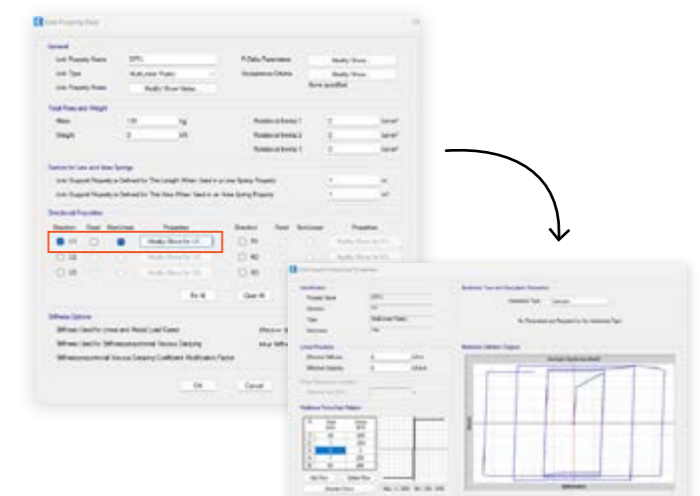

BRACE DAMPER

Product Code*	Capacity		Design Displacement range****	
	kN	kips	mm	inch
DFFJ-BR-50**	50	10	± 25 to 300	1 to 12
DFFJ-BR-100	100	20	± 25 to 300	1 to 12
DFFJ-BR-150	150	35	± 25 to 300	1 to 12
DFFJ-BR-200	200	45	± 25 to 300	1 to 12
DFFJ-BR-250	250	55	± 25 to 300	1 to 12
DFFJ-BR-300	300	65	± 25 to 300	1 to 12
DFFJ-BR-350	350	80	± 25 to 300	1 to 12
DFFJ-BR-400	400	90	± 29 to 300	1 to 12
DFFJ-BR-450	450	100	± 25 to 300	1 to 12
DFFJ-BR-500	500	110	± 25 to 300	1 to 12
DFFJ-BR-550	550	125	± 25 to 300	1 to 12
DFFJ-BR-600	600	135	± 25 to 300	1 to 12
DFFJ-BR-650	650	145	± 34 to 300	1 to 12
DFFJ-BR-700	700	155	± 25 to 300	1 to 12
DFFJ-BR-750	750	170	± 25 to 300	1 to 12
DFFJ-BR-800	800	180	± 25 to 300	1 to 12
DFFJ-BR-850	850	190	± 25 to 300	1 to 12
DFFJ-BR-900	900	200	± 25 to 300	1 to 12
DFFJ-BR-950	950	215	± 25 to 300	1 to 12
DFFJ-BR-1000****	1000	225	± 25 to 300	1 to 12

* The DFFJ-BR range has equal displacement in tension and compression

** The design displacement can be specified

*** The Maximum Displacement available in the device is typically twice the specified design displacement

**** For design capacities above 1000 kN, customized devices can be designed (at no extra cost) and/or multiple devices can be used in parallel

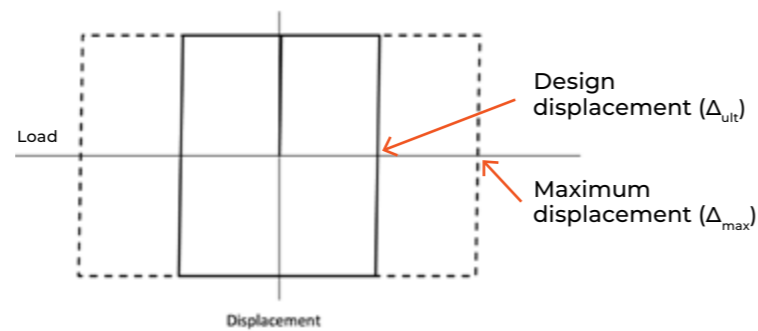
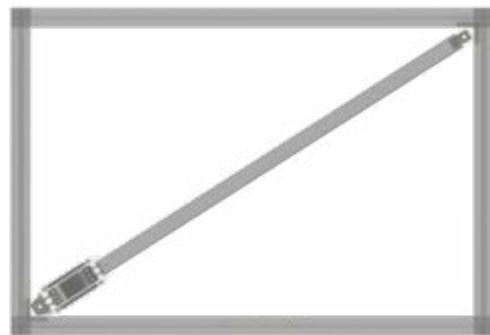

Tectonus DFFJ-BR range can be installed in parallel to increase the capacity of the brace. Customized DFFJs with $F_{slip} > 1000$ kN can be designed according to the requirements of the project.

SHEARWALL DAMPER

Product Code*	Capacity		Design Displacement range****	
	kN	kips	mm	inch
DFFJ-SW-50***	50	10	± 25 to 300	1 to 12
DFFJ-SW-100	100	20	± 25 to 300	1 to 12
DFFJ-SW-150	150	35	± 25 to 300	1 to 12
DFFJ-SW-200	200	45	± 25 to 300	1 to 12
DFFJ-SW-250	250	55	± 25 to 300	1 to 12
DFFJ-SW-300	300	65	± 25 to 300	1 to 12
DFFJ-SW-350	350	80	± 25 to 300	1 to 12
DFFJ-SW-400	400	90	± 25 to 300	1 to 12
DFFJ-SW-450	450	100	± 25 to 300	1 to 12
DFFJ-SW-500	500	110	± 25 to 300	1 to 12
DFFJ-SW-550	550	125	± 25 to 300	1 to 12
DFFJ-SW-600	600	135	± 25 to 300	1 to 12
DFFJ-SW-650	650	145	± 25 to 300	1 to 12
DFFJ-SW-700	700	155	± 25 to 300	1 to 12
DFFJ-SW-750	750	170	± 25 to 300	1 to 12
DFFJ-SW-800	800	180	± 25 to 300	1 to 12
DFFJ-SW-850	850	190	± 25 to 300	1 to 12
DFFJ-SW-900	900	200	± 25 to 300	1 to 12
DFFJ-SW-950	950	215	± 25 to 300	1 to 12
DFFJ-SW-1000*****	1000	225	± 25 to 300	1 to 12

* The DFFJ-SW range is typically specified for shear wall applications and has a swivel bearing to provide out-of-plane displacement compatibility

** The DFFJ-SW range has higher displacement in tension and lower in compression to be used as shear wall applications

*** The design displacement can be specified

**** The Maximum Displacement available in the device is typically twice the specified design displacements in tension and compression

***** For design capacities above 1000 kN, customized devices can be designed (at no extra cost) and/or multiple devices can be used in parallel

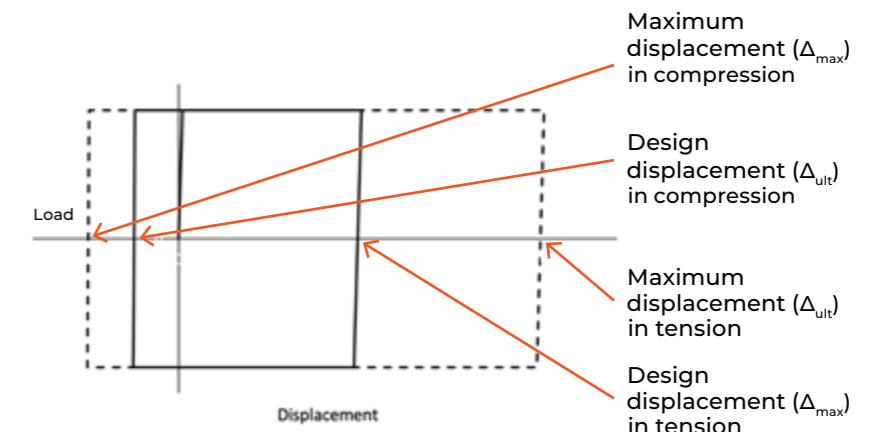
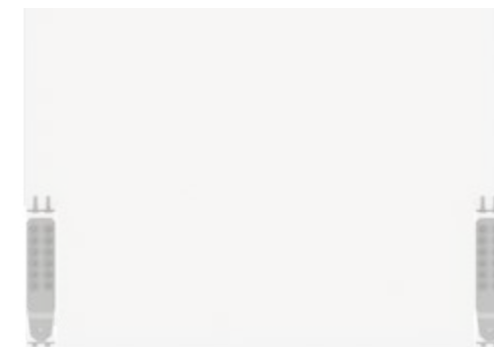

The Tectonus DFFJ-SW range can be installed in parallel to increase the capacity of the hold-down. Customized DFFJs with $F_{slip} > 1000$ kN can be designed according to the requirements of the project.



**FROM DESIGN
TO SITE**



The beauty of the Tectonus device is that it is incredibly tuneable and the performance is accurately measurable. We can confirm that it does what it is meant to by running performance tests and seeing the response.

Pierre Quenneville
Professor, Founder and CTO, Tectonus

PRODUCTION & QUALITY CONTROL

100% PERFORMANCE TESTED

During production, each and every device is tested up to the ultimate capacity specified by the designers. Performance testing is done to ensure that the load-displacement response of the device is within +/- 5% of the specified behavior (RSFJ). This is unique to the Tectonus devices as they do not yield or experience any damage. Performance test results are matched to the device serial plate number and provided in a project test report to clients.

MANUFACTURED & TESTED IN NEW ZEALAND

Manufacturing and assembly are performed in the Tectonus facility. Our fabrication suppliers go through strict vetting processes to ensure standards match our requirements.

INTERNATIONAL CONTROL STANDARDS

Tectonus uses stringent quality control processes across every stage of the project design, manufacturing and performance testing. The facilities and management systems run to international standards which are audited regularly:

- ISO9001 Management Standards
- AS/NZS Manufacturing Standards

Third Party quality inspections of our supplier partners are conducted regularly ensuring additional measures of quality assurance to AS/NZS Standards.



TESTING CAPABILITIES

Tectonus does in-house testing within its facilities and has access to external commercial and university partner facilities for:

- Quasi-static testing
- Dynamic high speed testing

Tectonus encourages project engineers to come and witness the performance testing of their project devices.



DELIVERY & INSTALLATION

Tectonus devices are assembled and tested at our purpose built facility in Auckland, New Zealand.

Delivery

Tectonus devices are delivered to site pre-tested, certified and ready to perform. The devices only need to be bolted into place.

Delivery times of 2-6 months are typical depending on configuration and location.

Connections

At the start of each project, following the receipt of the order, shop drawings are sent for review to coordinate bolt hole locations. The type of application will dictate the type of end connection of the device. The Tectonus team work with project partners to find the best fit for each site.

Shipment and Storage

Tectonus shipments arrive secure in crates and can be stored on site with appropriate weather protection. Following installation, the devices should be wrapped or encased to provide protection.

Braces

Brace devices are normally shipped to the brace fabricator who assembles the entire brace components for subsequent erection. Tight fabrication tolerances allow for a minimum of onsite adjustments.

Shearwalls

Shearwall hold-downs arrive on site ready to be bolted to the walls and anchored. Depending on project construction requirements, this can be customized.

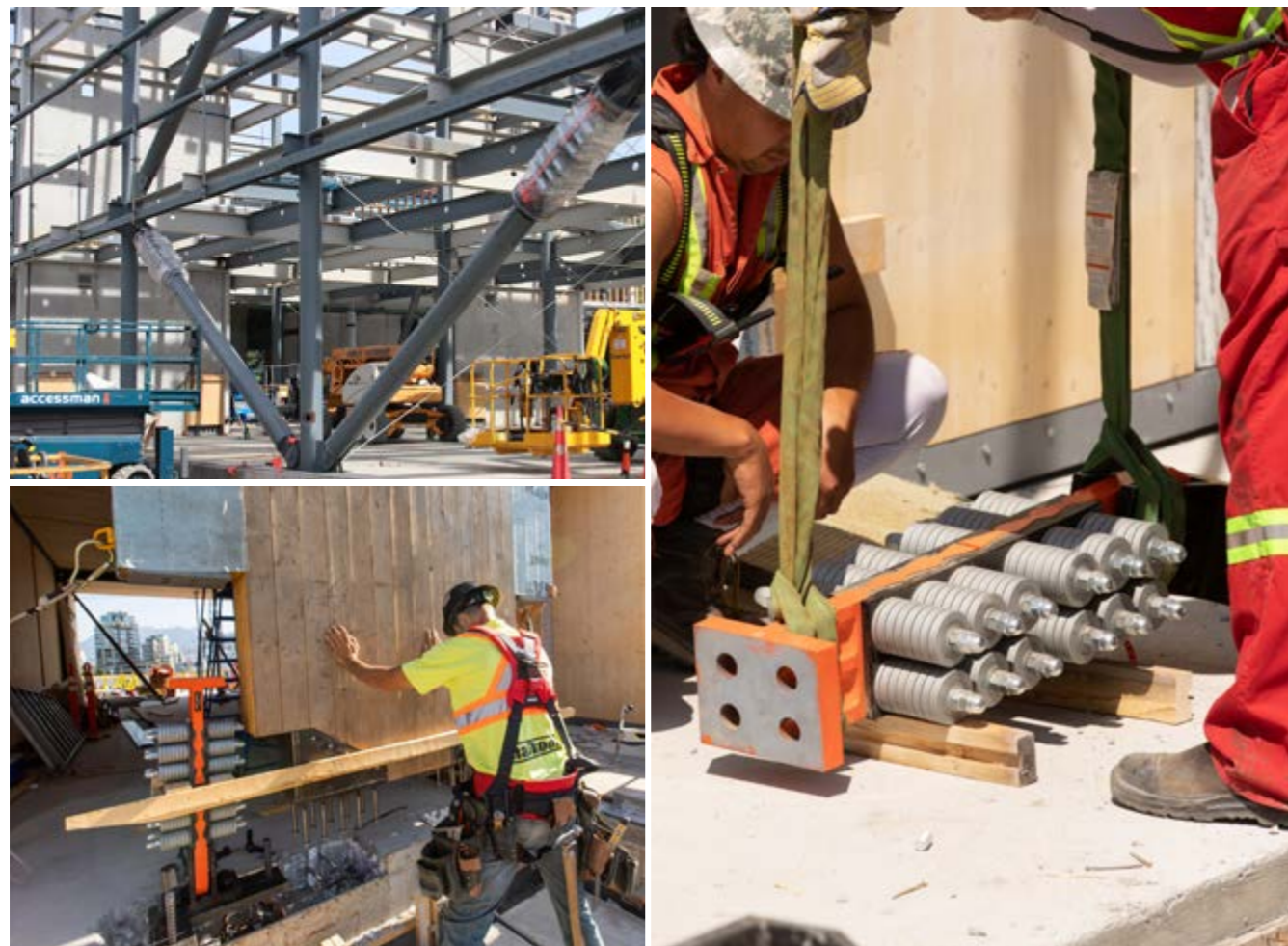

FINISHINGS – COLOURS & COVERS

Tectonus devices can be coloured, covered and fire protected according to the needs of the project. For more details please contact us.

Colour

Colour is fully customizable. If no colour is specified, then the brand colours will be used:

- Tectonus Orange (R 255 G 82 B 0)
- and Black.

Fire Resistance

Tectonus friction dampers can be fire protected according to the required standards using either intumescent paint or steel covers or a combination of both. The application of intumescent paint does not alter the capacity of the friction damper to dissipate energy or change its performance in any way.

Corrosion Resistance

Tectonus friction dampers are shipped to site with two layers of epoxy-based paint to provide an ISO 9223 C2 category. During construction, the dampers should be wrapped to protect them from rain.

Humidity Protection

In situations where the friction dampers are likely to be exposed to rain or salt spray, the dampers should be covered by a shroud to protect them from direct rain or moisture.

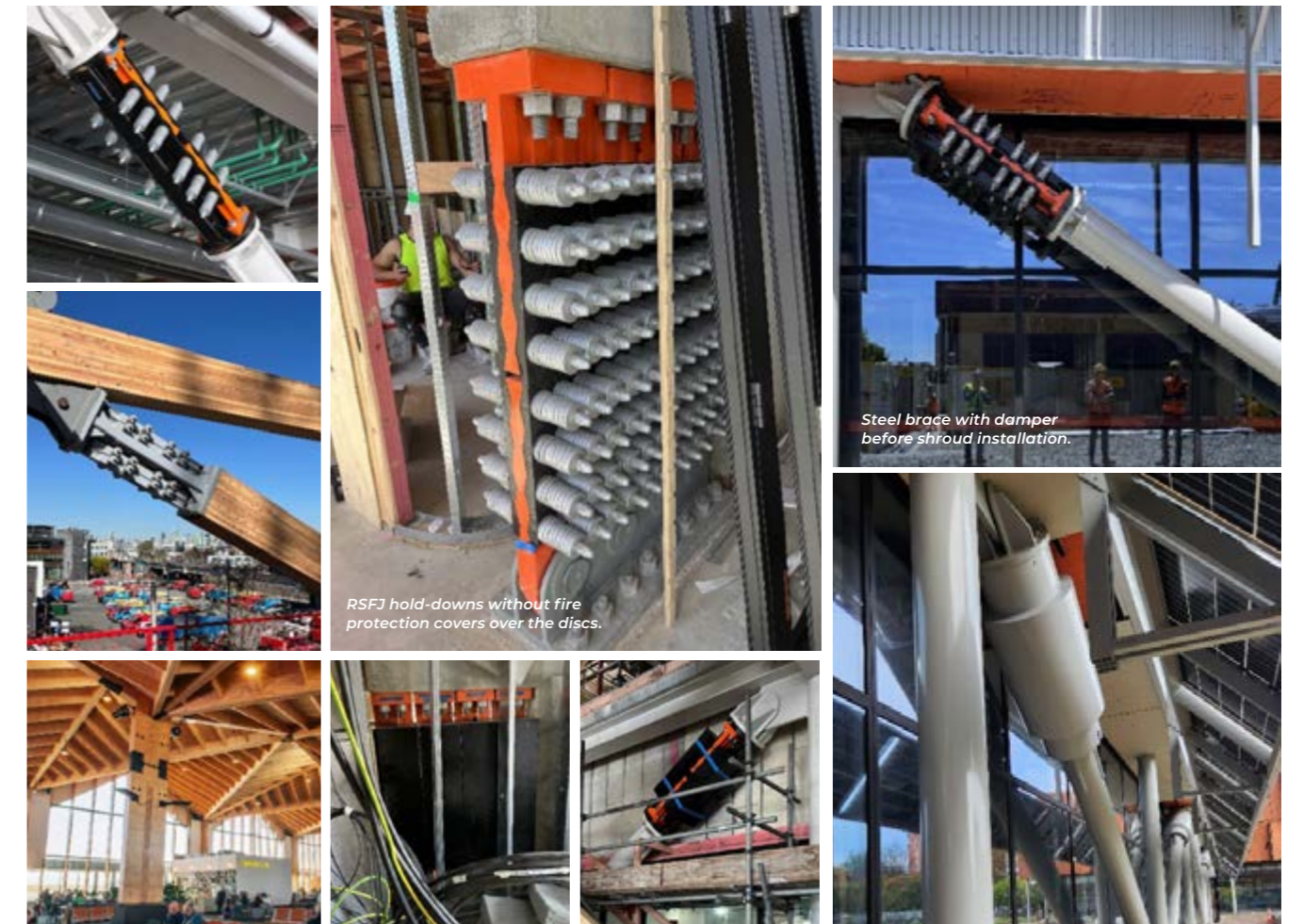

This column shows examples of dampers with brand colours and custom colour schemes.

Same RSFJ hold-downs as top picture, with fire protection covers with intumescent paint over the discs.

RSFJ brace with fire protection covers (with intumescent paint) over the discs.

This picture shows the same steel brace as above, with damper shroud installed.

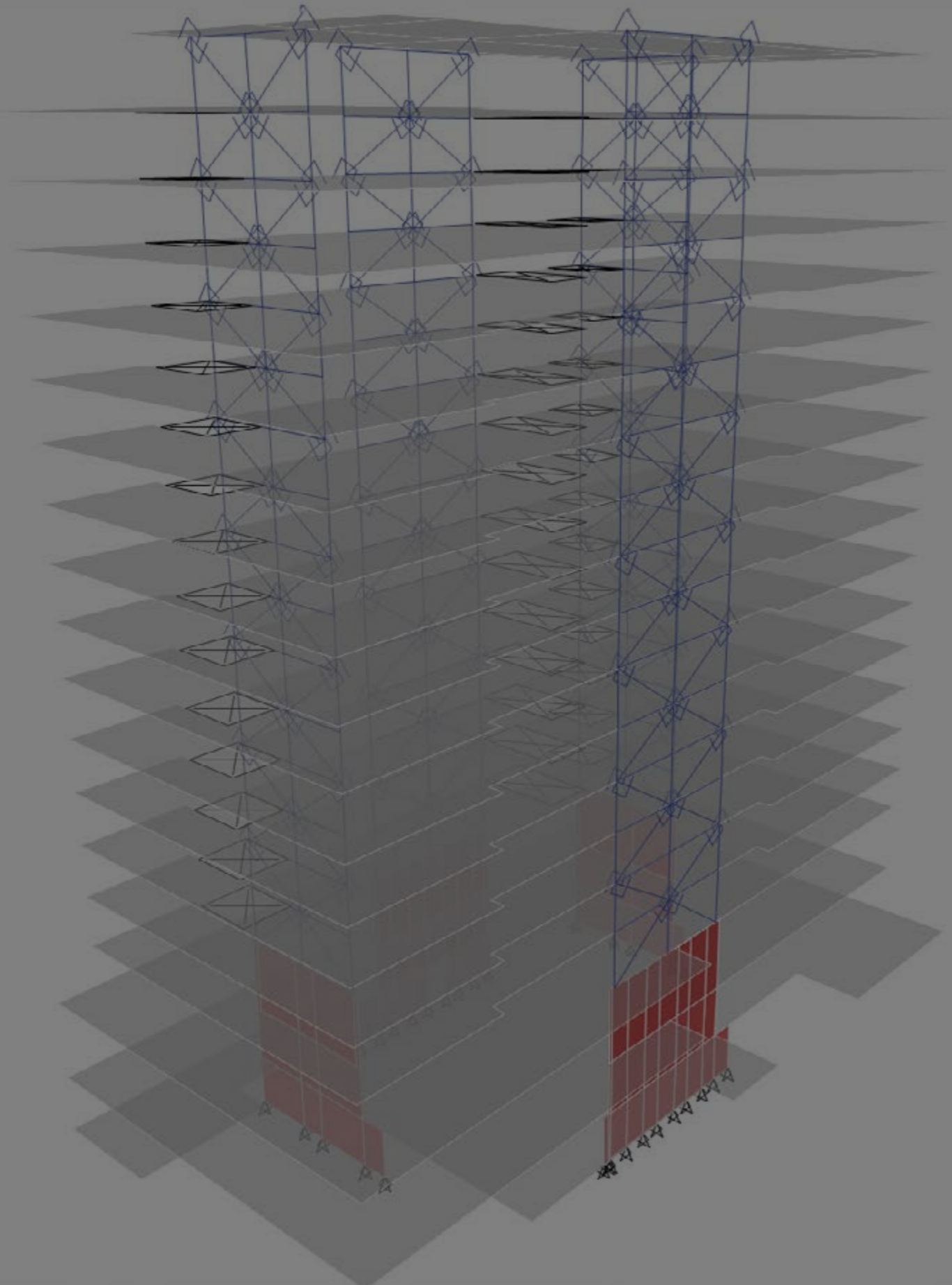

TECHNICAL SUPPORT SERVICES

Tectonus' in-house engineering team supports structural designers to get the very best results for their clients

The Tectonus team works closely with design engineers and contractors to provide the best fit seismic solution for each project – from design to installation.

Our engineers leverage their extensive technical knowledge, research and industry experience to identify potential design and construction challenges and provide effective solutions to mitigate risks and ensure the project's success.

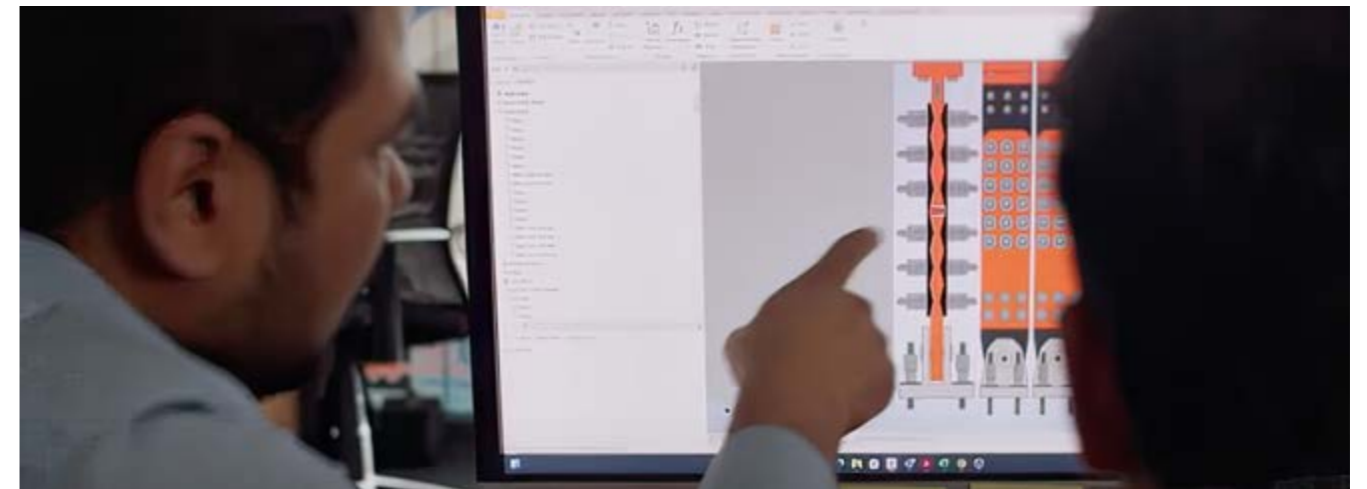

Compliance

Tectonus complies and adhere with global standards and guidelines:

- ASCE 7 & ASCE 41
- EC8
- NZS1170.5
- NBCC
- API 650
- NZSEE 'Seismic Design of Storage Tanks'
- AWWA D100

Engineering Modeling

- Non linear time history analysis
- Linear / displacement based design methods
- Structural modelling using ETABS, SAP2000
- Connection design
- Performance-based design

Calculator Tool

Visit the Tectonus website to access the online device capacity calculator. The tool generates the device parameters that can be used to start designing in ETABS/SAP2000.



EMAIL INFO@TECTONUS.COM FOR

- ✓ Presentations and Consultations
- ✓ Connection and Structural Modelling Analysis
- ✓ Impact studies





TEST RESULTS

COMPONENTS & SYSTEMS

RSFJ Component Test Dynamic Performance (as per ASCE 7-16)

As part of our ongoing testing program, a 350kN device was tested at Auckland University of Technology's Structures Lab to ascertain its dynamic performance according to ASCE 7-16.

The test set up and results are summarized here. The full report is available on request.

Background

The efficiency of friction-based dampers depends on stable frictional resistance on the sliding surfaces to provide reliable energy dissipation. Providing consistent performance has been one of the challenges with friction-based dampers, given possible strength degradation due to surface erosion and wearing under cyclic loads or dependency of the interface coefficient of friction to the sliding velocity under dynamic loads (dictated by the building frequency during an earthquake).

The Tectonus device sliding surfaces are treated by a special high-tech material sourced from aerospace applications. The surface treatment results in high thermal stability, addressing the challenge of consistent performance evident with other friction dampers.

To demonstrate this, the dynamic performance of Tectonus device was tested at the Structures Lab of Auckland University of Technology (AUT). Tests were witnessed by an independent Chartered Professional Engineer who is also a member of the New Zealand Society of Earthquake Engineering (NZSEE).

Test Specifications

The loading protocol was specified as per ASCE 7-16, providing a rigorous testing regime to verify the dynamic performance of the device.

The number and amplitudes of the loading cycles were as follows:

- 10 cycles at 15mm (37.5% of the maximum displacement)
- 5 cycles at 30mm (75%)
- 3 cycles at 40mm (100%)

The testing program included two different tests with the following frequencies:

- Test #1: Quasi-static at 0.1Hz (3 cycles at 100% displacement)
- Test #2: Dynamic at 1.0Hz (as per ASCE 7-16)

The Tectonus device tested comprised of 6 bolts (3 on each side) with a total capacity of about 350kN / 78 kips. The test setup included two 250kN MTS dynamic actuators paralleled to provide the capacity and the high frequency needed for this dynamic test validation.

Dynamic Testing Results

The results of the joint dynamic performance (at 1.0 Hz) and quasi-static performance (at 0.1 Hz) are presented (top right) demonstrating the compatibility of the hysteresis curves after simulated severe events without stiffness and strength degradation. Comparing the dynamic testing with quasi-static shows the velocity independence of the Tectonus device performance.

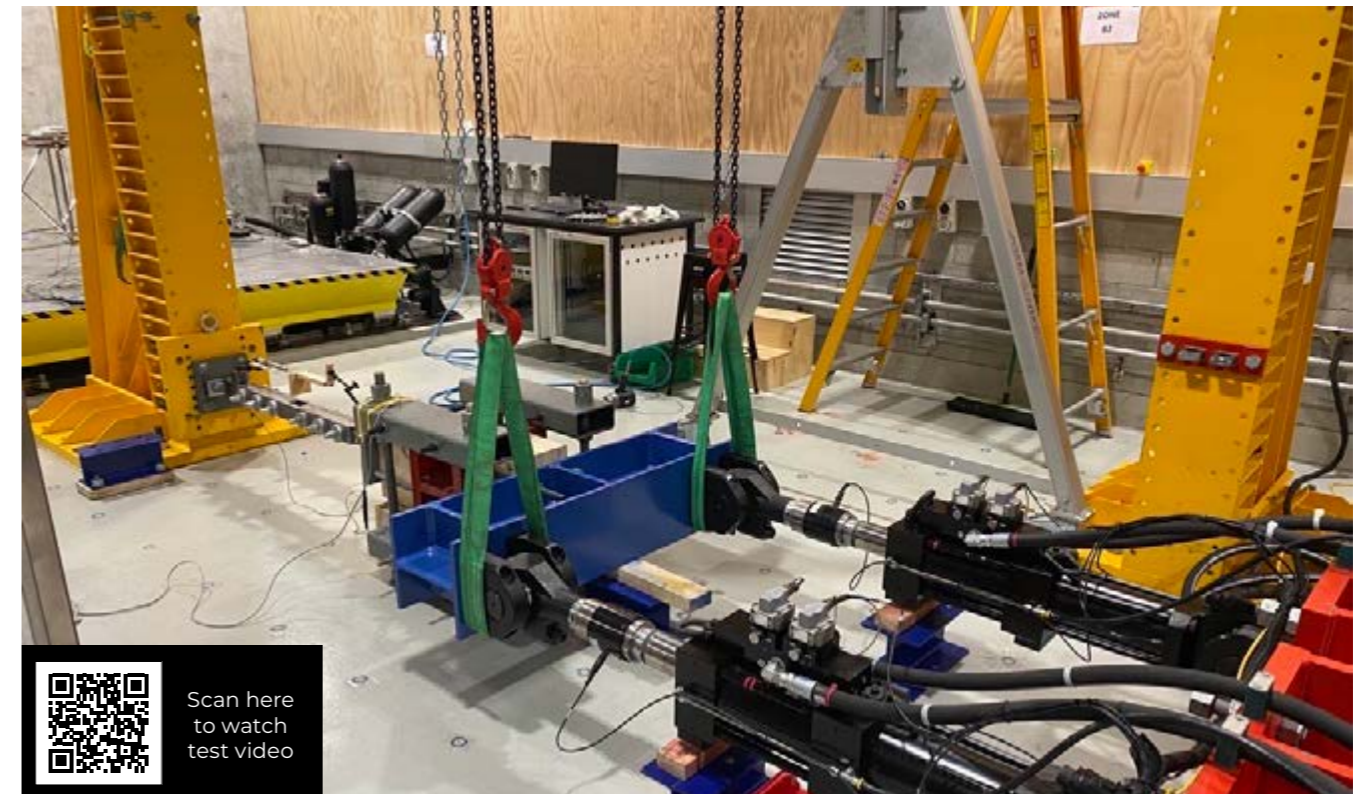
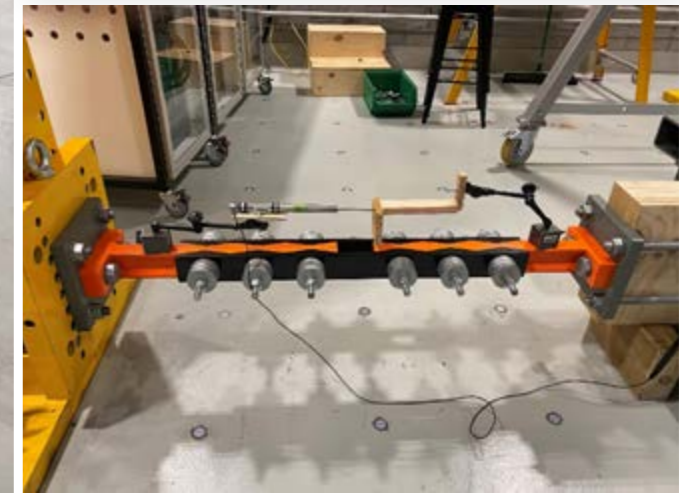
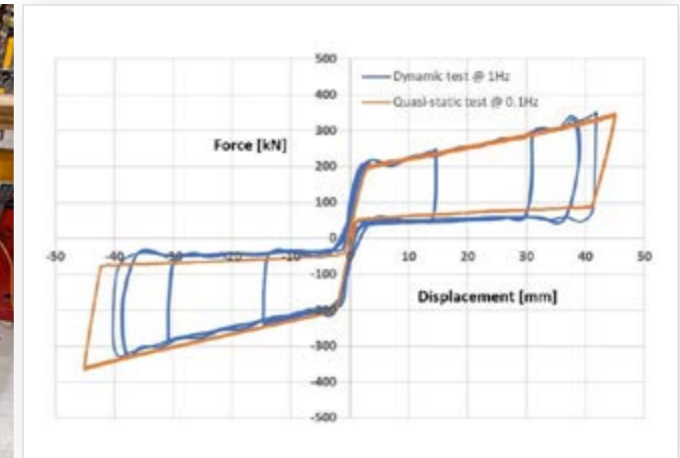

Scan here
to watch
test video

RSFJ Shake Table Tests Various Systems

Advancing seismic safety, a collaborative research by New Zealand and Tongji University teams has pioneered shake-table tests on friction damping devices, setting new benchmarks in structural resilience.

The test set up and results are summarized here. The full report is available on request.

Background

A consortium of university researchers (The University of Auckland, Auckland University of Technology and Canterbury University) from New Zealand and Tongji University have undertaken shake-table tests of various friction damping devices. The three RSFJ configurations tested are: tension-compression braces, tension-only cross-bracing and the moment resisting frame configuration.

Testing was at ILEE Testing Laboratory at Tongji University, China. The test structure has three storeys and planar dimensions of 7.25 x 4.75m, constructed of composite floors and steel columns with additional mass blocks added to impose a uniform load of 3.5kPa for the first floor and 4.7kPa for the second. The building is assumed to be located in Wellington soil class C and 5 km distant from the nearest fault.

Test Specifications

Configuration 1: steel tension and compression braces with RSFJs and anti-buckling tubes on diagonal steel braces located on levels one and two

Configuration 2: tension only cross bracing with RSFJs connected to diagonal steel rods in either direction

Configuration 3: In this concept, the RSFJs, as the self-centring components, are placed at the bottom flange of the beam and the positive and negative moments are provided through joints axial actions in tension and compression

All three configurations followed the same testing sequence: beginning with a 180 second white noise shaking the level of excitement is gradually increased beginning with 0.8 times SLS and progressively increasing to 1.2 times ULS in accordance with ROBUST collective agreement. 1.2 times ULS shaking is equivalent to ground motion excitation with peak ground acceleration (PGA) of 0.49g. Both the tension-compression and MRF configurations of the RSFJ were tested unidirectionally as well as bidirectionally, while the tension-only configuration was tested unidirectionally.

Testing Results

In tests of the three RSFJ congregations, complete self-centeredness is demonstrated. From the smallest magnitude of 0.8 times SLS to 1.3 times ULS, complete self-centring is achieved. Numerically, and now with the tests, it has been demonstrated that RSFJs can be effectively tuned to determine a structure's stiffness and deformation profile. This structure is numerically tuned so that the top story does not require bracing, while distributing the drift demand proportionally, and it is demonstrated that this can be achieved in full scale structures through the tuning of the force-displacement ratio of each RSFJ. In all three configurations, flag-shaped hysteresis is consistent and reliable regardless of the number of shaking excitations. Each of the three configurations demonstrated consistent and reliable flag-shaped hysteresis behaviour across multiple seismic excitations while providing effective damping and energy dissipation capabilities, with no observed damage to the components or structural elements involved.

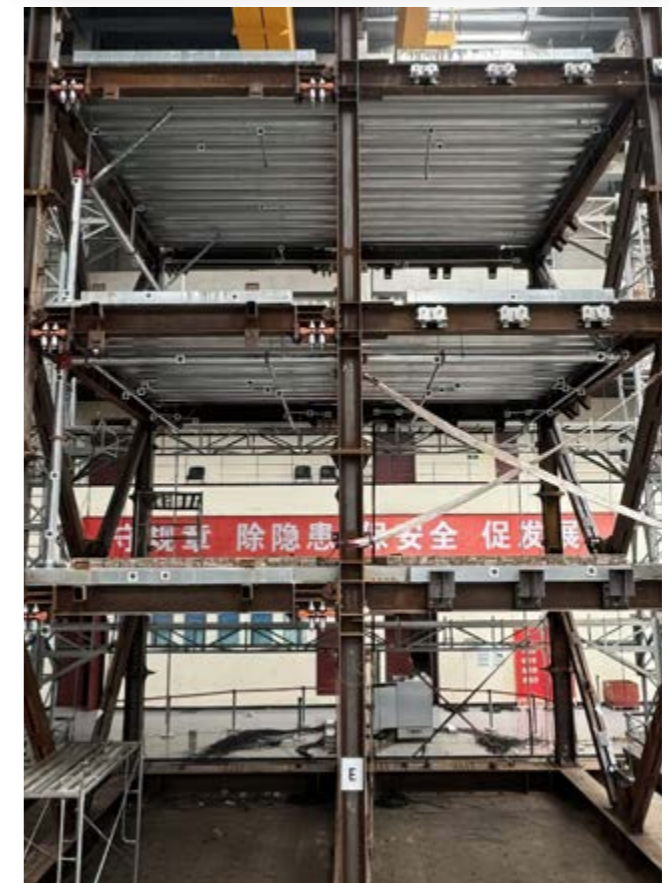
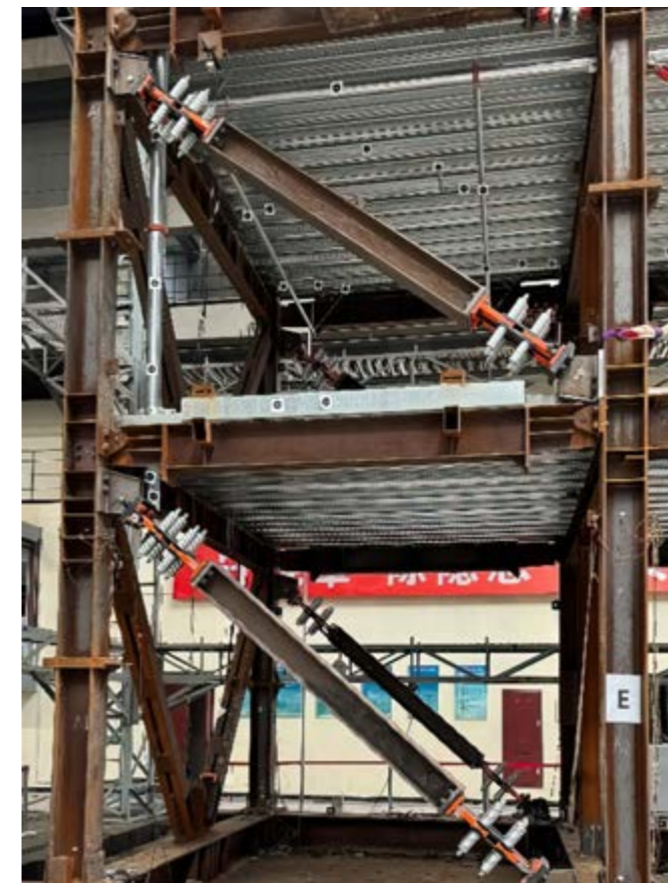
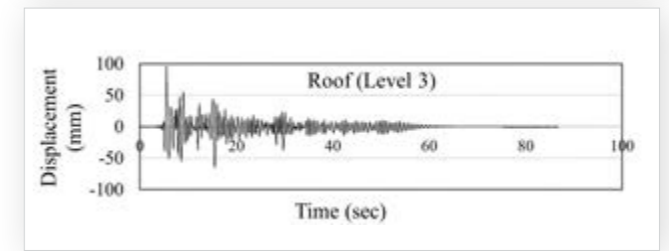
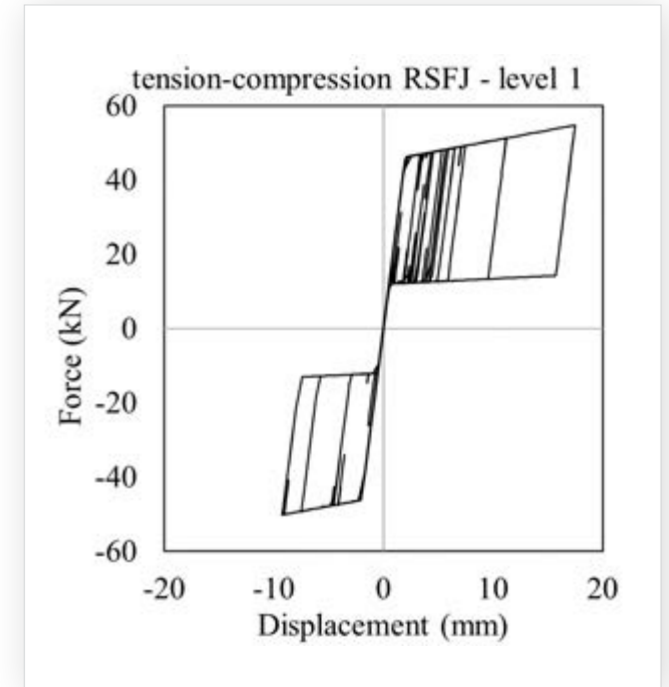

Steel / RSFJ Tension & Compression Brace

This large-scale test demonstrated Tectonus devices as a damage avoidance seismic connection that provides highly ductile tension and compression steel braces with self-centering capability.

Also investigated was a new anti-buckling mechanism introduced for this bracing system to control the lateral stability of the brace under compression forces. Alone, braces have relatively inferior behaviour in the inelastic zones due to the pinching, strength and stiffness degradation. Without added resilience, braces are at risk of failure during and following seismic events.

Test Specifications

- Two Tectonus devices (in parallel) were used at both ends of a large-scale steel brace with I-section
- Each device had a capacity of about 125kN = 250kN total, and
- Deflection capacity of about 50mm, allowing for about 2% drift
- Dynamic loading protocol as per AISC 341 at 0.4Hz

Results

- The Tectonus Brace system was able to withstand the seismic input energy with a repetitive response while self-centring was achieved consistently
- No maintenance was required between test cycles
- The anti-buckling system performed efficiently, controlling the lateral stability of the brace and prevented any rotation to be imposed to the devices affecting their performance.

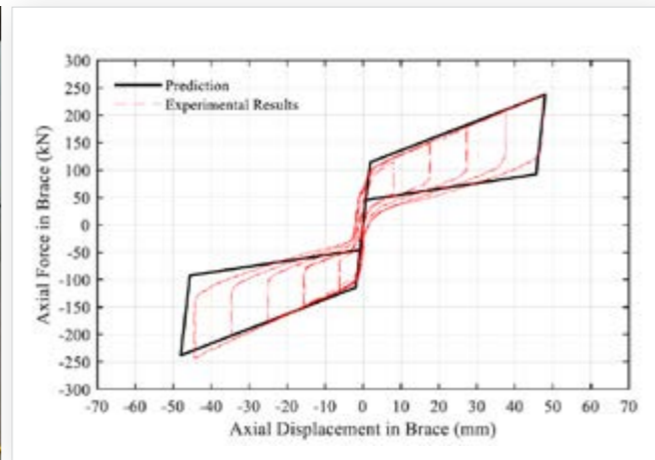

Steel / RSFJ Toggle Brace

This large-scale test demonstrated the Tectonus devices as a damage avoidance seismic connection that provides highly ductile steel toggle braces with self-centering capability for retrofitting of deficient reinforced concrete frames.

Also investigated was the connections designed for transferring the resistance force of the toggle brace to the current frame.

Test Specifications

- Two Tectonus devices (in parallel) were used at one end of a steel toggle brace
- Each device had a capacity of about 50kN = 100kN total, and
- Deflection capacity of about 40mm, allowing for about 1.5% drift
- Quasi-static loading protocol as per ISO 13033

Results

- The system damping was improved by over 50% (even though limited at a low drift of 1.5%).
- Toggle brace force amplification factor of about 1.3 was achieved (compared to about 0.7 in case of diagonal brace)
- The Tectonus Toggle Brace system was able to withstand the seismic input energy with a repetitive response while self-centring is achieved consistently (with no pinching)
- No maintenance was required between test cycles
- The brace end connections performed efficiently, transferring the brace forces to the existing frame.

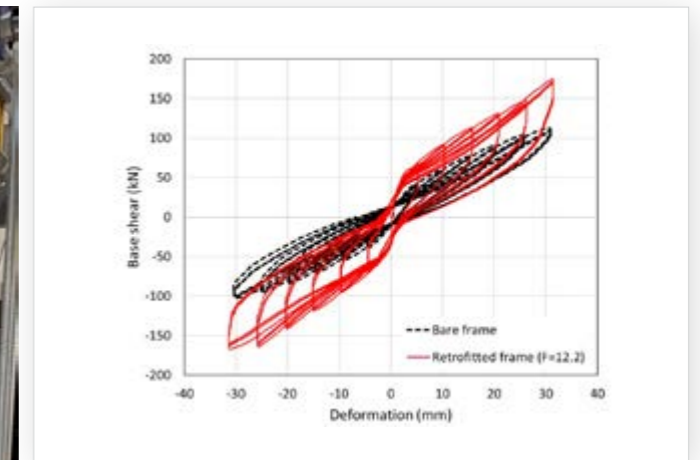

Timber / RSFJ Tension & Compression Brace

This full-scale test demonstrated the Tectonus devices as a damage avoidance seismic connection that provides highly ductile tension and compression timber braces with self-centering capability.

Also investigated was a new anti-buckling mechanism introduced for this bracing system to control the lateral stability of the brace under compression forces.

Test Specifications

- Two Tectonus devices (in parallel) were used at one end of a full-scale glulam timber brace
- Each device had a capacity of 200kN = 400kN total, and
- Deflection capacity of about 45mm, allowing for about 2% drift
- Quasi-static loading protocol as per ISO 13033

Results

- The Tectonus Brace system was able to withstand the seismic input energy with a repetitive response while self-centering is achieved consistently
- No maintenance was required between test cycles
- The anti-buckling system performed efficiently, controlling the lateral stability of the brace and prevented any rotation to be imposed to the devices affecting their performance

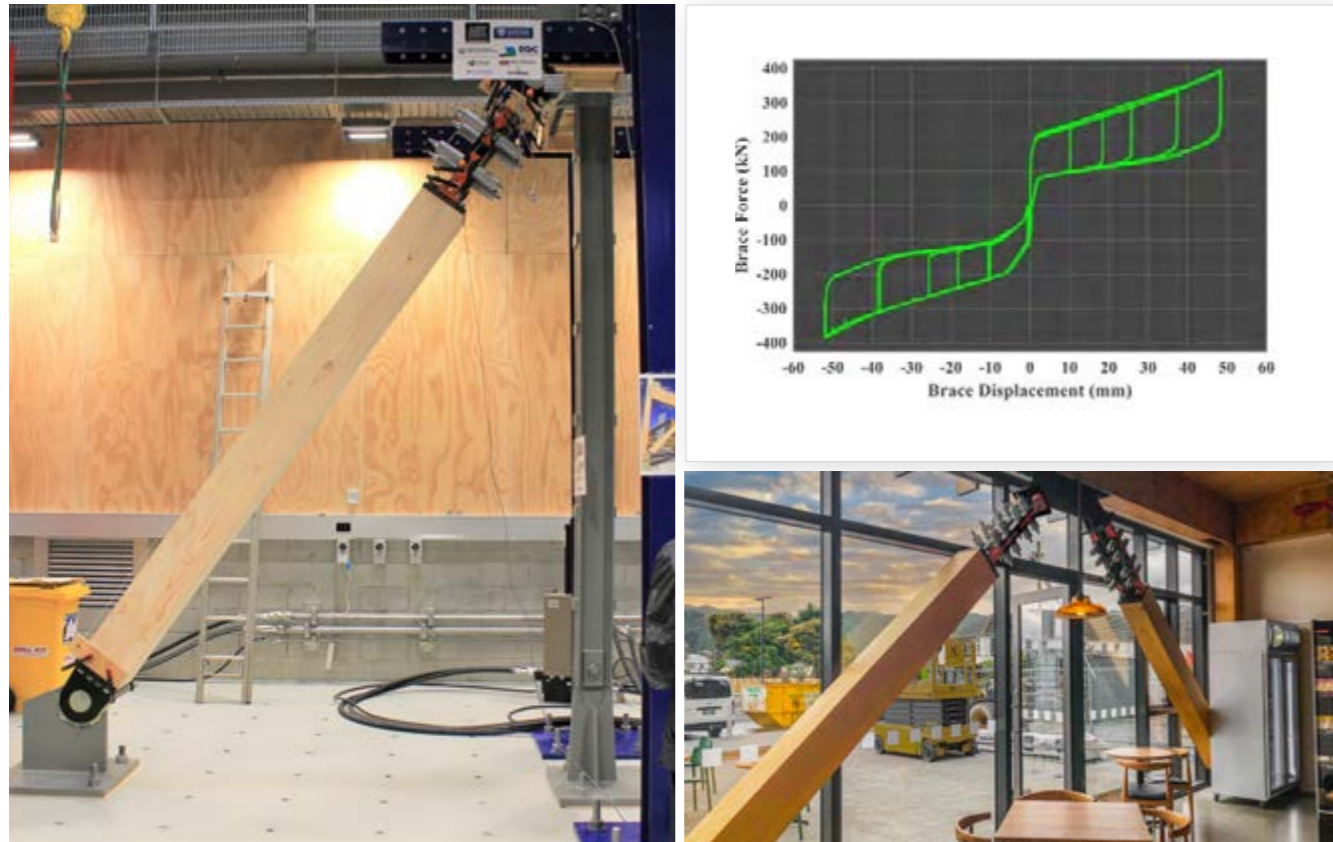

Concrete / RSFJ Shearwall

Full-scale test with the Tectonus devices in a pre-cast concrete shearwall was performed to demonstrate the technology as an effective damage avoidance system.

The seismic hold-downs provide a highly ductile rocking shearwall with self-centering capability.

Test Specifications

- Tectonus devices were used as hold-downs at each corner of a large-scale prefabricated concrete shearwall
- Each device had a capacity of about 150kN
- Deflection capacity of about 40mm, allowing for about 2.5% drift
- Quasi-static loading protocol as per ISO 13033

Results

- System could withstand seismic input energy with repetitive response whilst continuously self-centering following each cycle
- No maintenance or reconfiguration was required
- Use of pin and swivel at the bottom end of the device satisfied the deformation capability required for the shearwall efficient performance and control of damage during bidirectional loading

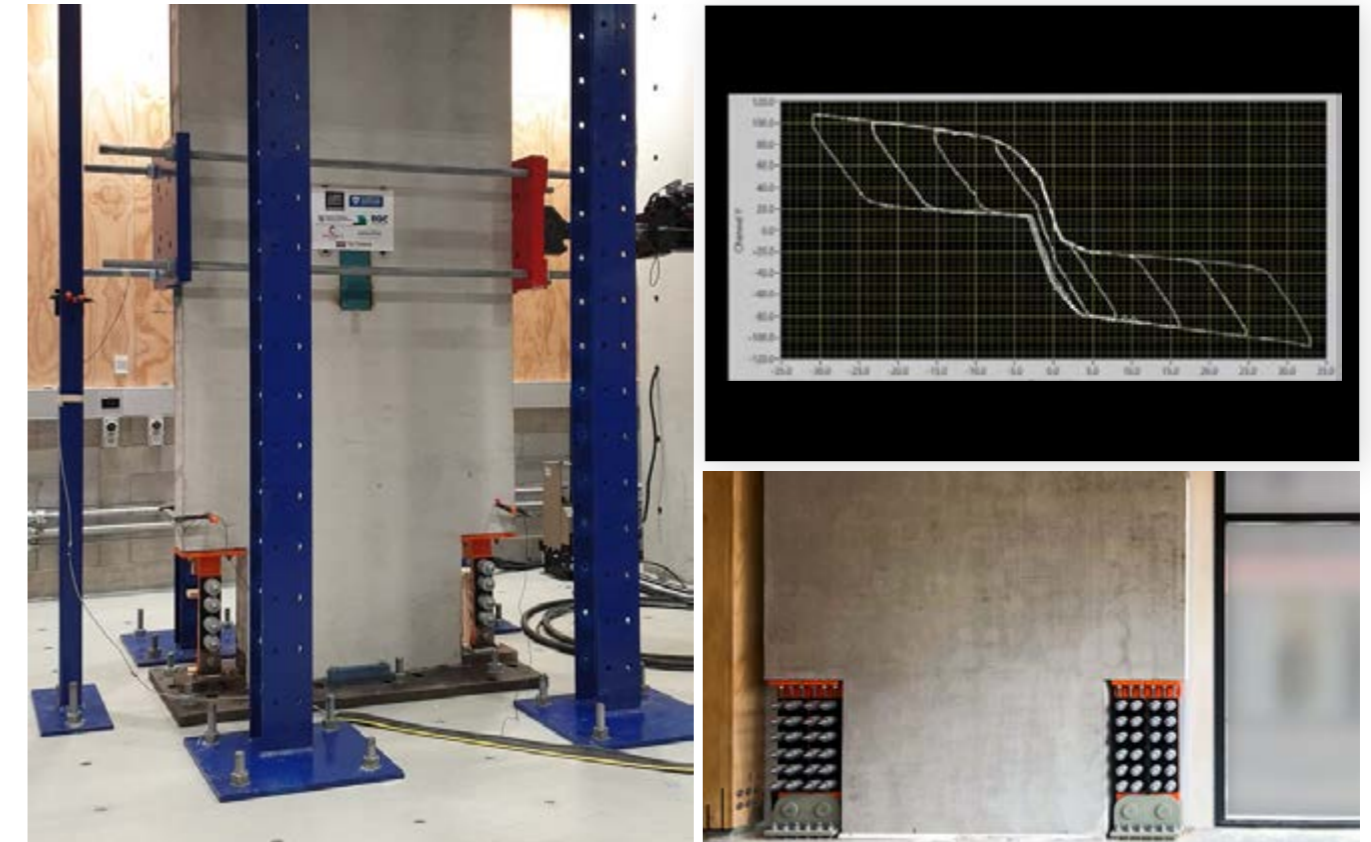

Timber / RSFJ Shearwall

Full-scale test with the Tectonus devices in a CLT shearwall was performed to demonstrate the technology as an effective damage avoidance system.

The seismic hold-downs provide a highly ductile rocking shearwall with self-centering capability.

Test Specifications

- Tectonus devices were used as hold-downs at each corner of a large-scale CLT shearwall
- Each device had a capacity of about 50kN
- Deflection capacity of about 40mm, allowing for about 2.5% drift
- Quasi-static loading protocol as per ISO 13033

Results

- System could withstand seismic input energy with repetitive response whilst continuously self-centring following each cycle
- No maintenance or reconfiguration was required
- Use of pin at the devices end connections satisfied the deformation capability required for the shearwall efficient performance and control of damage

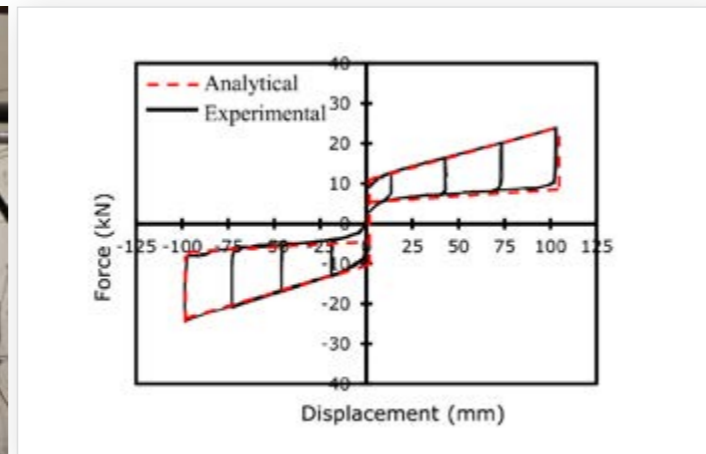

Timber / RSFJ Column

Full-scale test with the Tectonus devices in a LVL column was performed to demonstrate the technology as an effective damage avoidance system.

The seismic base connections provide a highly ductile rocking column with self-centering capability.

Test Specifications

- Tectonus devices were used as base connections at each corner of a full-scale LVL column
- Each device had a capacity of about 1000kN
- Deflection capacity of about 20mm, allowing for about 2.5% drift
- Quasi-static loading protocol as per ISO 13033
- In-plane, out-of-plane and bidirectional loading

Results

- System could withstand seismic input energy with repetitive response whilst continuously self-centring following each cycle
- No maintenance or reconfiguration was required
- Use of pin and swivel at the bottom end of the devices satisfied the deformation capability required for the column efficient performance and control of damage during bidirectional loading

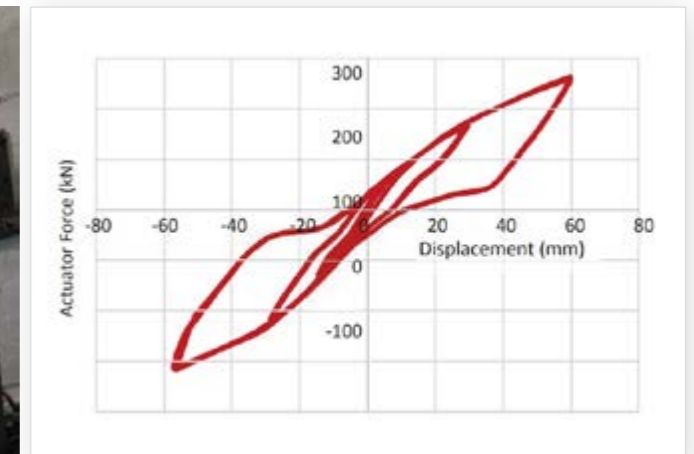

Steel / RSFJ Tension-only Brace

Large-scale test with the Tectonus devices in a steel rod tension-only brace was performed to demonstrate the technology as an effective damage avoidance system.

The Tectonus cross-bracing system does not exhibit the detrimental pinching effect that plagues the usual cross-bracing systems. In addition, the system is designed so that out-of-plane buckling of the shortening brace is avoided.

Test Specifications

- Tectonus devices were used at the end connections of a steel rod cross-bracing
- Each device had a capacity of about 250kN
- Deflection capacity of about 65mm, allowing for over 2.5% drift
- Dynamic loading protocol as per AISC 341 at 0.3 Hz

Results

- The Tectonus system performed effectively without any maintenance between cycles
- No out-of-plane buckling of the “shortening” brace
- Secondary fuse of the device is effective in providing additional safety
- Threaded rod reliability is paramount to minimise device over-strength factor
- Test provided repetitive and consistent results in line with the technology specifications for self-centering and maintenance free seismic protection

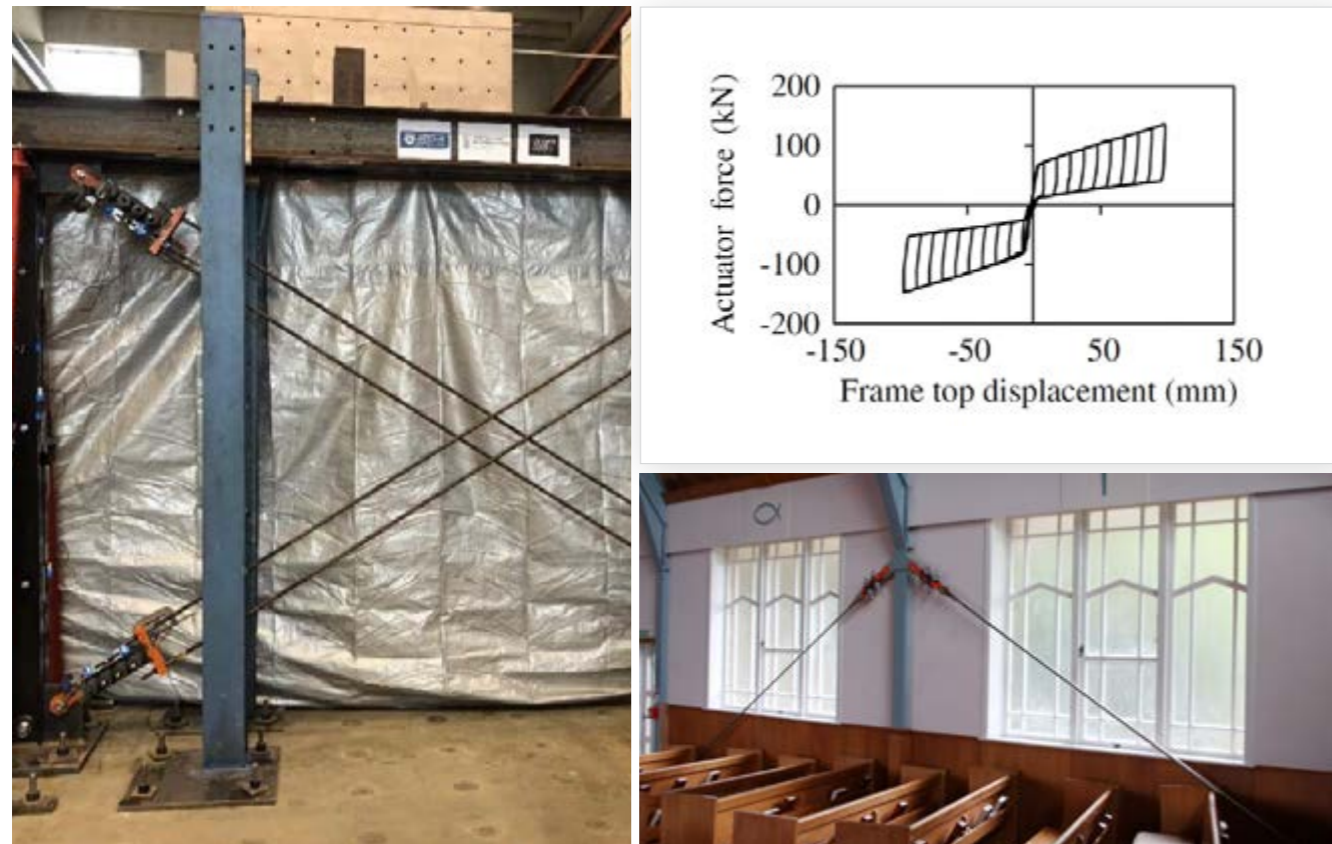

Steel / RSFJ Moment Resisting Frame

Large-scale test with the Tectonus device in a beam-to-column moment resisting connection was performed to demonstrate the technology as an effective damage avoidance system.

The Tectonus devices perform in tension and compression and, for this test, were placed in the bottom flange of the beam. This placement prevents the gap opening at the top of the beam and controls floor slab cracking. The top connection could be a pin or a bolted plate detailed to be flexible enough to act as a hinge. It is possible to implement the devices in specific bays and floors to take advantage of cost efficiencies.

Test Specifications

- Two Tectonus devices (in parallel) were used as steel beam bottom connections
- The top of the steel beam was pinned to the column
- Each device had a capacity of about 250kN
- Deflection capacity of about 15mm, allowing for over 2.5% drift
- Quasi-static loading protocol as per ISO 13033

Results

- The Tectonus system dampens and mitigates earthquake impact in a MRF application effectively
- Use of a pin at the top of the beam as well as in the device connection ends provided the required strain compatibility
- Test provided repetitive and consistent results in line with the technology specifications for self-centering and maintenance free seismic protection

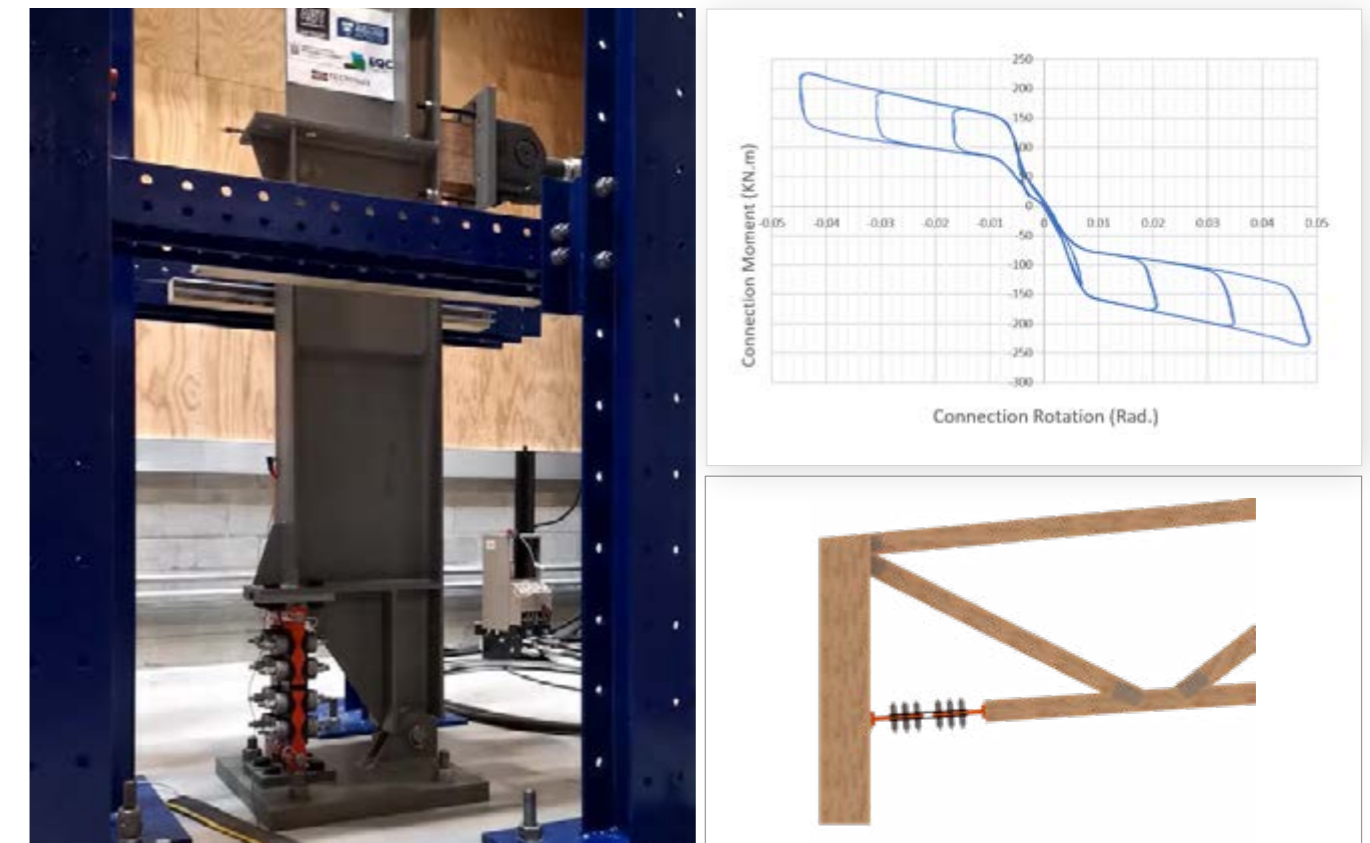

DFFJ Component Test Dynamic Performance (as per ASCE07-16)

Background

The efficiency of friction-based dampers depends on stable frictional resistance of the sliding surfaces to provide reliable energy dissipation. Achieving consistent performance in friction-based dampers is a challenge because of either strength degradation resulting from surface erosion and wearing under cyclic loads, or dependency of the interface coefficient of friction to the sliding velocity under dynamic loads (dictated by the building frequency during an earthquake).

Tectonus DFFJ utilizes a special friction material on the sliding surfaces, with outstanding resistance to wear, excellent stability and high hardness, addressing the aforementioned challenges on the conventional sliding friction connections. To demonstrate that, the dynamic performance of Tectonus DFFJ was tested at the Structures Lab of the Auckland University of Technology (witnessed by an independent Earthquake Engineer, MEngNZ).

Test Specifications

The loading protocol was specified as per ASCE07-16 providing a rigorous testing regime to verify the dynamic performance of the DFFJ (at the frequency of 0.45Hz). The number and amplitudes of the loading cycles have been:

The number and amplitudes of the loading cycles were as follows:

- 10 cycles at +/-24mm (37.5% of the maximum displacement)
- 5 cycles at +/-49mm (75%)
- 3 cycles at +/-65mm (100%)

The Tectonus DFFJ comprised of 8 bolts with multi sliding layers, with a capacity of about 330kN. The test setup included two 250kN MTS dynamic actuators paralleled to provide the capacity and the high frequency needed for this dynamic test validation.

Dynamic Testing Results

The results of the joint dynamic performance demonstrate the compatibility of the hysteresis curves after simulated severe events without any stiffness and strength degradation. It should be noted that the performance tolerances are below 10% (significantly lower than other friction dampers) resulting in a very low overstrength factor critical for having an efficient capacity design of the adjacent members, in particular for retrofitting projects.

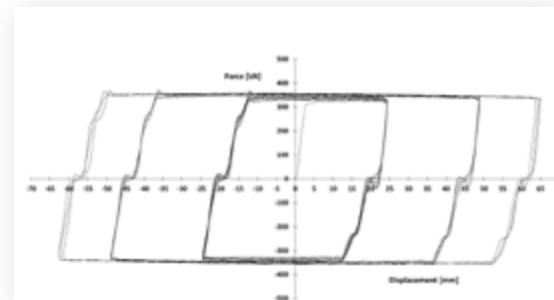

DFFJ Component Test Dynamic Performance (as per EN15129)

Background

The efficiency of friction-based dampers depends on stable frictional resistance of the sliding surfaces to provide reliable energy dissipation. Achieving consistent performance in friction-based dampers is a challenge because of either strength degradation resulting from surface erosion and wearing under cyclic loads, or dependency of the interface coefficient of friction to the sliding velocity under dynamic loads (dictated by the building frequency during an earthquake).

Tectonus DFFJ utilizes a special friction material on the sliding surfaces, with outstanding resistance to wear, excellent stability and high hardness, addressing the aforementioned challenges on the conventional sliding friction connections. To demonstrate that, the dynamic performance of Tectonus DFFJ was tested at the Structures Lab of the Auckland University of Technology (witnessed by an independent Earthquake Engineer, MEngNZ).

Test Specifications

The Tectonus damping device tested comprised of 2 bolts with a capacity of about 60 kN/13.5 Kip. The loading protocol was specified as per EN15129 providing a rigorous testing regime (more severe than ASCE7-16 given the higher number of averaged full cycles) to verify the dynamic performance of the device.

The number and amplitudes of the loading cycles were as follows:

- 5 cycles at +/- 6.25mm (25% of the maximum displacement)
- 5 cycles at +/- 12.5mm (50%)
- 10 cycles at +/- 25mm (100%)

The testing program included four different tests with the following sequences and frequencies. The quasi-static tests were performed at five full cycles and the dynamic tests as per the above loading protocol:

- Test #1: Quasi-static at 0.1Hz
- Test #2: Quasi-static at 0.2Hz
- Test #3: Dynamic at 1.0Hz
- Test #4: Dynamic at 2.0Hz

Dynamic Testing Results

The results of the device dynamic performance (at 1.0 & 2.0 Hz) and quasi-static performance (at 0.1 & 0.2 Hz) demonstrate the compatibility of the hysteresis curves after simulated severe events without stiffness and strength degradation.

Comparing the dynamic testing with quasi-static shows the velocity independence of the Tectonus DFFJ.

A full test report is available upon request.

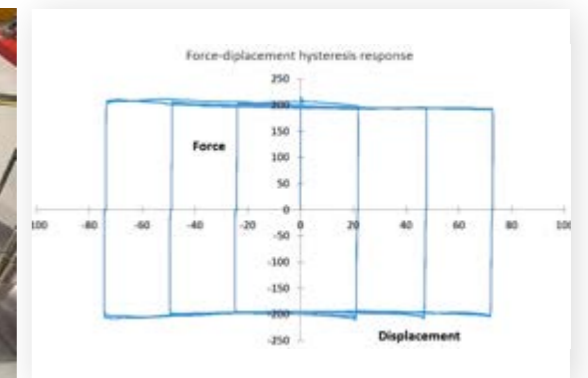

Steel / DFFJ Tension & Compression Brace

The Tectonus Damage-Free Friction Joints (DFFJ's) provide efficient damping and ductility for brace applications. The high consistency and very low tolerances of the dynamic performance of Tectonus DFFJ's have been the significant advantages when compared to other friction-based dampers available in the market. It should be noted, while friction dampers have sufficient capacity at the component level to resist the local buckling under compression forces, that would not be the case for brace applications. Providing lateral stability for brace applications has always been a challenge because the initiation of friction sliding in the damper forms a plastic hinge resulting in brace global buckling at the damper location.

Tectonus incorporates anti-buckling telescopic tubes to provide the required stability. Incorporating the anti-buckling mechanism has shifted the weak point of buckling from the damper location to the brace body itself, leading to a much higher brace capacity.

Test Specifications

To demonstrate the dynamic performance of Tectonus DFFJ brace, a full-scale testing has been conducted at the Structures Lab of the Auckland University of Technology (witnessed by an independent Earthquake engineer, MEngNZ). The loading protocol was specified as per ASCE07-16 providing a rigorous testing regime (at the frequency of 0.45Hz). The number and amplitudes of the loading cycles have been:

- 10 cycles at +/-15mm (37.5% of the maximum displacement)
- 5 cycles at +/-30mm (75%)
- 3 cycles at +/-40mm (100%)

Results

The results of the brace dynamic performance is presented below, demonstrating the compatibility of the hysteresis curves after simulated severe events without any stiffness and strength degradation as a result of brace buckling or joint performance compromise.

It should be noted that the performance tolerances are below 10% (significantly less than other bracing systems such as BRB with 80-100%) resulting in a very low Overstrength Factor (OSF). A low OSF enables cost saving through efficient capacity design of the adjacent members, in particular for retrofitting projects.

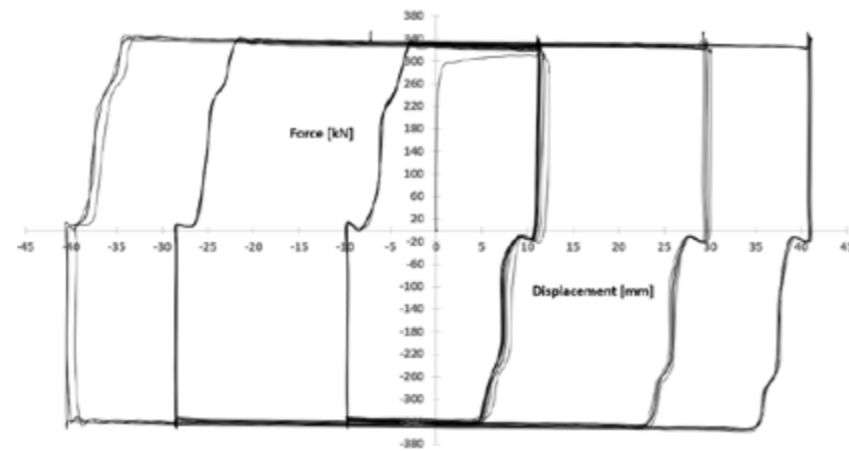

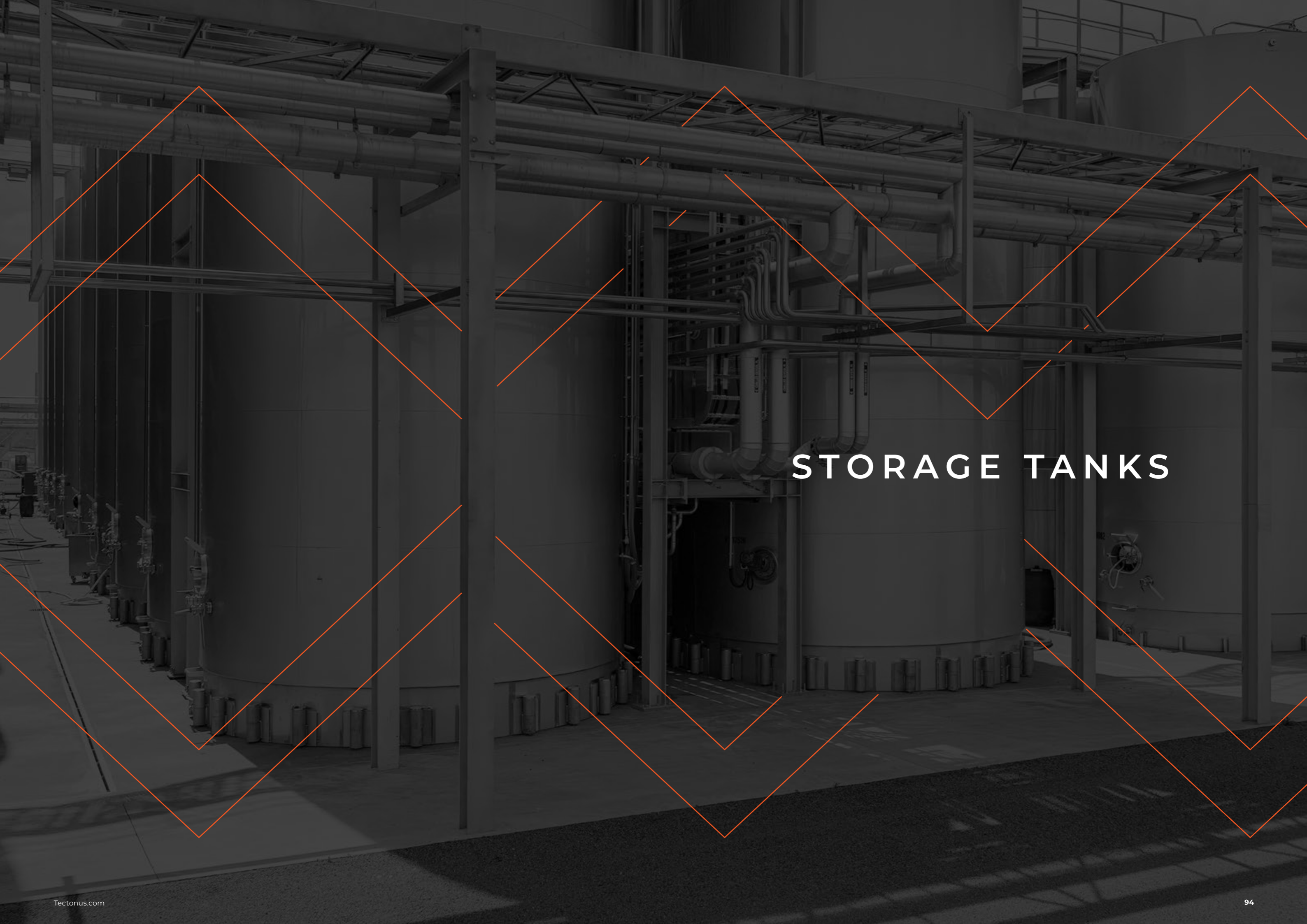

STORAGE TANKS



DFFD-RSFD TANK ANCHORS

Seismic Protection for Storage Tanks

Tectonus makes seismic tank anchors that attach to the foot of the tank, making it seismically compliant and saving on material costs by lowering the seismic demand, and ensuring you won't lose your tank and its contents in an earthquake event.

Save money on build costs

Compared to traditional tank anchors, Tectonus devices lower seismic demand which can save on build costs:

- Reduce concrete foundation thickness by up to 35%
- Reduce tank thickness by up to 3mm or 1/8 inch

Material savings typically outweigh the additional cost of the anchors, making it a cost positive investment.

Save money if there's an earthquake

Tectonus tank anchors are designed to absorb the energy impact of an earthquake.

- Protect your tanks
- Protect your people
- Protect your product
- Protect your profits

Unlike other tank anchors, Tectonus anchors do not yield or break, meaning there is nothing to repair or replace, and they keep on protecting you through aftershocks.

DFFD

low to medium aspect ratio tanks

Suited to lower aspect ratio tanks where the tank has sufficient mass to recentre itself.

100kN capacity with Overstrength Factor of 1.15

Installation

- Mechanical attachment
- Can be done offsite

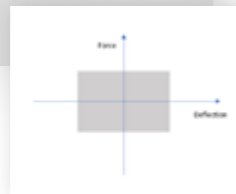
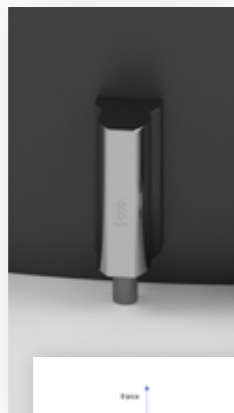

RSFD

medium to high aspect ratio tanks

Suited to high aspect ratio tanks where recentering force needs to come from the tank anchors themselves.

150kN capacity with Overstrength Factor of 1.25

Installation

- Welding
- Typically done on site

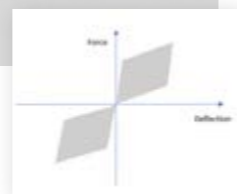

YEALANDS WINERY, BLENHEIM

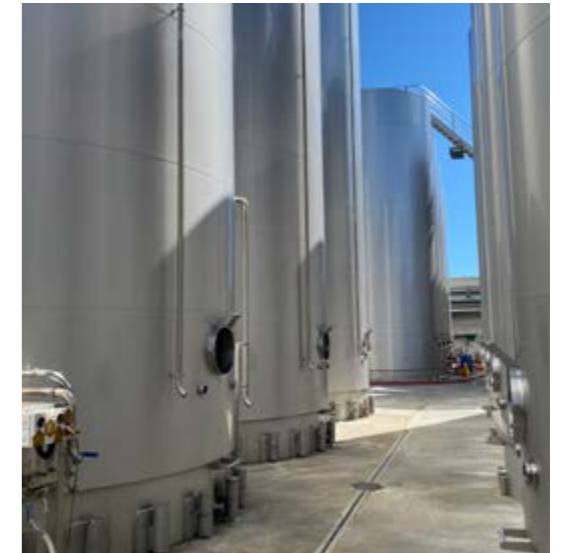

Background

Yealands Winery, located in Blenheim, New Zealand, is a leading wine producer with an annual output of 1.6 million cases. Operating in an area prone to seismic activity, the winery faced the challenge of safeguarding their tank storage facilities to ensure business continuity and protect their valuable assets. To address this, Yealands turned to Tectonus seismic anchors, a cutting-edge solution designed to provide optimal performance across different aspect ratios and content types.

- Yealands, a New Zealand winery with annual production of 1.6 million cases of wine
- 10 x 175kL tanks (10m x 4.7m)
- >30% reduction on the seismic load demand, compared to conventional systems
- 15% reduction in overall project cost through savings in the tank and foundation thickness
- Enabled the client to negotiate insurance terms, without shortening of the tanks to meet the insurers' original demand

The Challenge:

Yealands Winery faced the engineering challenge of fortifying their tank storage facilities against seismic events in Marlborough, New Zealand. Seeking an effective solution aligned with their requirements, Yealands implemented Tectonus seismic anchors. These adaptable devices provided the necessary protection for the storage tanks.

The Impact:

The integration of Tectonus seismic anchors had a significant impact at Yealands Winery. It resulted in a substantial reduction in seismic load demand, enhancing structural resilience and reducing the risk of damage during seismic events. The implementation also led to cost optimization by reducing overall project costs through thickness optimization of tanks and foundations. Yealands successfully met insurance requirements without modifying the original tank dimensions, ensuring uninterrupted operations and compliance.

The Outcome:

The successful implementation of Tectonus seismic anchors demonstrates the practical application of engineering solutions at Yealands Winery. By effectively protecting their tank storage facilities, Yealands ensured business continuity and operational resilience. This case study showcases the tangible benefits of employing the right seismic protection measures in seismically active regions. Discover how Yealands Winery leveraged Tectonus seismic anchors to fortify their tanks, enabling sustained success in the wine industry.



ABOUT US

SEISMIC INNOVATION

PART OF THE TECTONUS DNA

The Tectonus device was developed by our technical founders who tasked themselves with finding a long-term, resilient solution to the recurring problem of structural damage following seismic events.

Building on the long tradition of seismic engineering innovation in New Zealand, Tectonus was spun out of the University of Auckland in 2016.

Our close ties to the University of Auckland and Auckland University of Technology give access to talent, technology and testing facilities.

Continuous innovation is integral to our identify and central to our culture. These pages feature a selection of projects in the works.

We look forward to sharing more innovations with our project partners in the near future.



Storage Tanks

Tectonus has successfully deployed seismic devices protecting tanks in New Zealand wineries and dairy plants.

The tank devices are pre-tested to ensure capacity requirements are met and have additional advantages including:

- Providing multi-cycle protection so tanks can withstand numerous earthquakes without damage to tank wall
- No post event repair
- No replacement
- No sacrificial components



Structural Health

Tectonus Structural Health Monitoring solutions provide important insight to structural health by showing how Tectonus devices perform – either mechanically or digitally.

Mechanical Gauge

Mechanical gauges are attached to the Tectonus devices and show the maximum displacement the device experienced. Gauges are easy to visually inspect. See project on pg 27.

Digital Sensor

For continuous monitoring and real-time data collection without needing to enter the building, a digital sensor can be fitted on devices to collect and transmit performance data. Particularly useful in settings of high value properties.



Residential

Residential buildings in seismic prone areas are at risk of damage and/or costly repairs following earthquake events and aftershocks.

Tectonus is developing a device for residential and multi-unit residential builders and owners.

The device will provide:

- Cost effective seismic compliance
- Excellent seismic performance
- Enhanced structural integrity



Passion, talent and dedication have seen Tectonus grow from the humble beginnings of concentrated research efforts to milestone projects and now a global provider of seismic protection.



Nelson Airport protected by Tectonus

OUR JOURNEY

OUR VISION:
SAFER AND
MORE RESILIENT
COMMUNITIES

Carrying on New Zealand's rich tradition in seismic innovation, we are driven to set a higher standard for earthquake resilience.

The Beginning

After the Christchurch Earthquakes, more than 70% of central city buildings were demolished because the level of residual drift made it uneconomical to repair them.

Tectonus' founders, then academics at the University of Auckland, started working on solutions to recentre a building after an earthquake so that residual drift would be close to zero. The technology was originally developed for mass timber then quickly applied to concrete and steel.

Tectonus was formed in 2016. Seven years on we've installed thousands of devices in more than 25 structures in New Zealand and Canada, with projects in development in USA and Japan.

Capabilities

We are experts in the seismic design of earthquake resistant structures, as well as technology developers. Our expertise in mass timber structures is second to none.

Our in-house engineering team are skilled in numerical modelling and analysis using linear and non-linear methods, and well versed in international standards: ASCE 7, ASCE 41, EC8, NBCC, and NZS1170.5.

The close relationship with University of Auckland continues, as well as Auckland University of Technology (AUT). These relationships give ongoing access to engineering talent, technology and testing facilities.

Since 2022 Tectonus has benefitted from professional management and is guided by an experienced Board made up of industry veterans.

Facilities

Tectonus is headquartered in Auckland, New Zealand's largest city, which straddles a narrow isthmus between the Pacific Ocean and Tasman Sea. Our seismic risk is similar to many other cities located on the Pacific Rim.

Assembly and testing takes place in our purpose built 14,000 square feet facility. As well as office, warehousing

and production areas we have three quasi static testing machines for production testing and R&D.

Thanks to close ties to AUT's Structures Lab we have access to a full scale dynamic testing facility.

Working Together

Structural engineers are our core constituents. We work closely with structural engineers, helping them to design innovative, elegant and resilient structures.

Architects are critical too, shaping expectations in terms of seismic resilience. Constructors bring the design to life and are the ones who procure and install the seismic devices from us. We're also connected with project managers, quantity surveyors and connection suppliers. It takes many hands to raise a building.

Clients who own and occupy and think long-term are most likely to see the value in enhanced seismic resilience. Government, institutions, healthcare, aged care, transport, energy, life science and technology businesses – all have assets that need to be fully operational immediately after an earthquake.

We can't stop earthquakes, but we can engineer a future where lives and livelihoods are better protected.. [Are you with us?](#)



Specialists in seismic engineering, we are driven to set a higher standard for earthquake resilience. Let's work together to make our cities and communities safer.

New Zealand

18 Greenpark Rd
Penrose
Auckland 1061
T. 0800 866 871
E. info@tectonus.com

USA / Canada

T. +1 888 440 9717
E. info@tectonus.com